



**➤ SEM315**

**DIN RAIL HART® TEMPERATURE TRANSMITTER**



Status Instruments Ltd, Green Lane Business Park, Tewkesbury, Glos. GL20  
8DE

Tel: +44 (0)1684 296818 ● Fax: +44 (0)1684 293746  
Email: sales@status.co.uk ● Web: www.status.co.uk

**➤ INDEX**

SECTION	CONTENTS	PAGE NO.
1.0	DESCRIPTION	1
2.0	SPECIFICATION	1-3
3.0	INSTALLATION	4-5
4.0	HART PROGRAMMING	5-7

## ➤ 1.0 DESCRIPTION

The SEM315 is a HART Din Rail temperature transmitter that accepts commonly used temperature sensor, slidewire transducer or millivolt signal and converts the output to the industry standard (4 to 20) mA transmission signal.

The software package M-config or a Hart Communicator with the necessary "Device Description" can be used to program the unit.

## ➤ 2.0 SPECIFICATION @ 20 °C

### ➤ 2.1 RTD INPUT (Pt100) 2, 3 OR 4 WIRE

Sensor Range		(-200 to 850) °C (18 to 390) Ω
Minimum Span <sup>1</sup>		25 °C
Linearisation		BS EN60751 (IEC 751) BS 1904 (DIN 43760), JISC 1604, CUSTOM [X] <sup>3</sup>
Max Lead Resistance		50 Ω per leg (balanced for 3 wire)
Basic Measurement Accuracy <sup>2</sup>		±0.01 % FRI ±0.07 % Rdg (FRI = Full Range Input)
RTD Excitation Current		(300 to 500) µA
Thermal Drift	Zero	0.008 °C / C
	Span	0.01% / °C

### ➤ 2.2 THERMOCOUPLE INPUT

Thermocouple Type	Measuring Range <sup>4</sup> °C	Minimum Span <sup>1</sup> °C
TC Type K	-200 to 1370	50
TC Type J	-200 to 1200	50
TC Type T	-210 to 400	25
TC Type R	-10 to 1760	100
TC Type S	-10 to 1760	100
TC Type E	-200 to 1000	50
TC Type L	-100 to 600	25
TC Type N	-180 to 1300	50
TC Type [X] <sup>3</sup>	User defined	

Linearisation	BS EN60584-01 BS 4937/IEC 584-1 (multi segment Polynomials)
Basic Measurement Accuracy <sup>2</sup>	0.04 % FRI ±0.04 % RDG or 0.5 °C (whichever is greater)
Thermal Drift	Span 0.01 % / °C
Cold Junction Error	±0.5 °C
Cold Junction Tracking	0.05 °C / °C
Cold Junction Range	(-40 to +85) °C

## ➤ 2. 3 MILLIVOLT INPUT

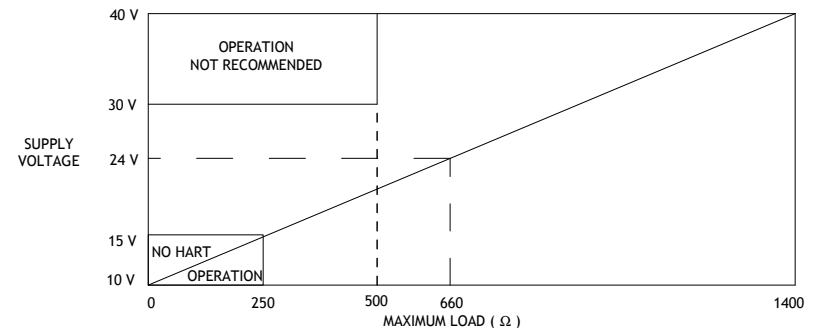
Input		Voltage Source
Range		(-10 to 75) mV
Characterisation		Linear, Custom [X] <sup>3</sup>
Minimum Span		5 mV
Basic Measurement Accuracy <sup>2</sup>		±10 µV ±0.07 % Rdg
Input Impedance		10 MΩ
Thermal Drift	Zero	0.1 µA / °C
	Span	0.01 % / °C

## ➤ 2.4 SLIDEWIRE INPUT

Input		3 Wire potentiometer
Resistance Range		(10 to 390) Ω (End to End) Larger values can be accommodated by fitting a link, see Figure 2.
Characterisation		Linear, Custom [X] <sup>3</sup>
Minimum Span <sup>1</sup>		5 % of FRI
Basic Measurement Accuracy <sup>2</sup>		0.1 % FRI
Thermal Drift	Zero	0.005 % of span / °C
	Span	0.01 % / °C
Range		(0 to 100) %

## ➤ 2.5 OUTPUT

Burnout Levels	Low 3.75 mA , High 21.5 mA
Input out of Range	Low 3.8 mA, High 20.5 mA
Output range	(4 to 20) mA, Min. 3.75 mA, Max. 21.5 mA
Accuracy	±5 µA
Thermal Drift	1 µA / °C
Supply Voltage <sup>5</sup>	(10 to 40) V
Supply Voltage effect	0.2 µA / V
Maximum output load	[(Vsupply-10)/21.5] KΩ. 250 Ω minimum loop load for correct HART operation. <sup>5</sup>



## Notes

- 1 Any span may be selected but full accuracy is only guaranteed for spans greater than the minimum recommended.
- 2 Includes the effect of calibration, linearisation and repeatability.
- 3 Custom characterisation is available pre-programmed at the factory. Contact your nearest Sales office.
- 4 Consult Thermocouple reference tables for practical temperature ranges.
- 5 For supply voltages over 30V, a minimum loop load of 500  $\Omega$  is necessary.

## ➤ 2.6 GENERAL

Input/Output Isolation	500 VAC
Time Constant (Filter Off)	0.5 secs (to 90 % of final value)
Filter Factor Programmable	Off / selectable between 1 and 32 seconds / or Adaptive
Warm-up Time	120 seconds to full accuracy

## ENVIRONMENTAL

Ambient Operating Range	(-40 to 85) °C
Ambient Storage Temperature	(-50 to 90) °C
Ambient Humidity Range	(10 to 95) % RH non condensing

## EMC

BS EN 61326

## MECHANICAL

Enclosure	DIN Rail mounted to fit DIN EN 50022-35
Material	ABS
Weight	70 g
Dimensions	(90 x 99 x 18.5) mm
Flammability	UL94-V0
Connections	Tension clamp two terminals and 3.5 jack for comms.

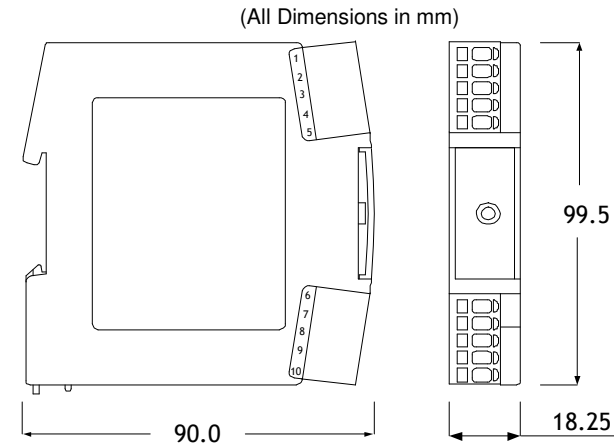
## ➤ 3.0 INSTALLATION

### ➤ 3.1 MECHANICAL

The transmitter is designed to mount onto a standard Din Rail. The transmitter should be installed with adequate protection from moisture and corrosive atmospheres. The transmitter may be mounted in any orientation.

Care must be taken when locating the transmitter to ensure the ambient temperature remains within the specified operating range. Figure 1 shows the mechanical layout of the transmitter

**Fig 1**

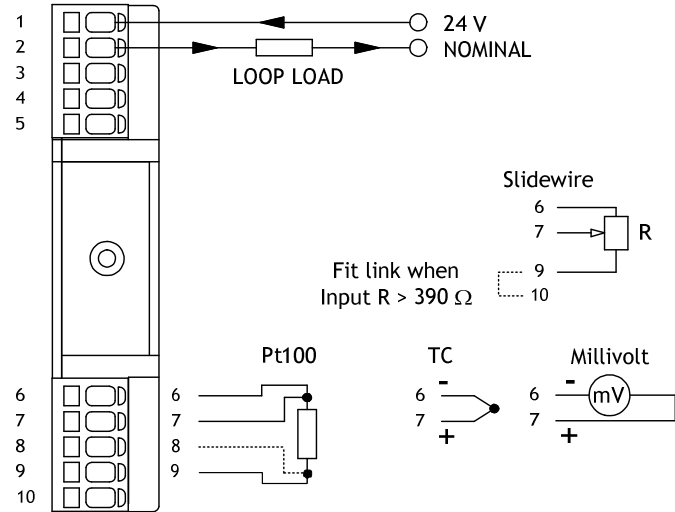


### ➤ 3.2 ELECTRICAL

Connections to the transmitter are made to the tension clamp terminals provided on the front face. Output signal wiring should use screened twisted pair. It is recommended that screened cable is used for the input signal wires for cable runs greater than one metre. For Pt100 inputs all input wires must have the same core diameter to maintain equal resistance in each wire.

Figure 2 shows the method of connection to provide a (4 to 20) mA current loop output. The output loop has a voltage power supply used to provide loop excitation. The load symbol represents other equipment in the loop, normally indicators, controllers or loggers. Care must be taken when designing the (4 to 20) mA circuit to ensure that the total voltage requirements of all the equipment in the loop added together, does not exceed the power supply voltage. If a number of instruments are connected in the loop, ensure that only one instrument is tied to ground. Grounding the loop at two points will cause a short circuit of part of the loop leading to measurement errors. To maintain CE compliance the transmitter should be mounted in an enclosure to prevent access to the transmitter during normal operation.

**Fig 2**



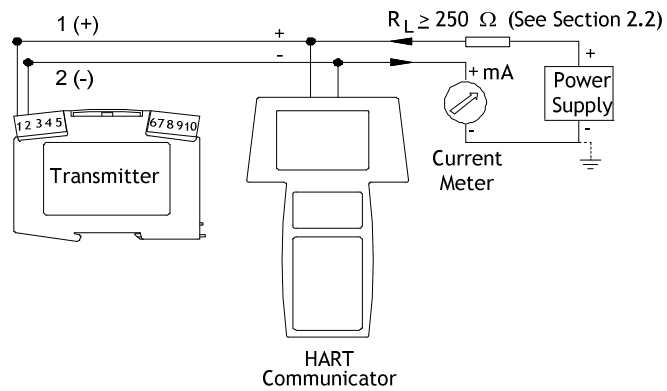
\* Resistance Range, (10 to 390) Ω (End to End) Larger values can be accommodated by linking terminals as shown.

**➤ 4.0 HART PROGRAMMING**

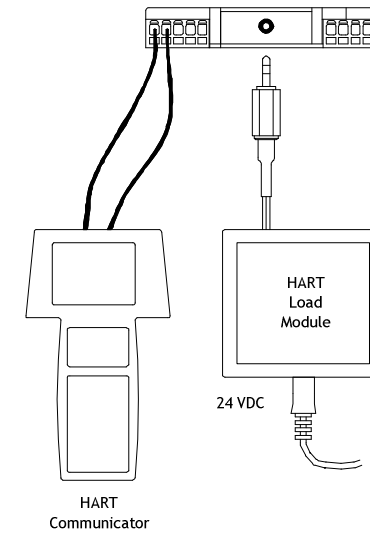
Consult HART website for more details: [www.hartcomm.org](http://www.hartcomm.org)

**➤ 4.1 CONNECTION ARRANGEMENT FOR HART COMMUNICATOR**

**Fig 3.1a**

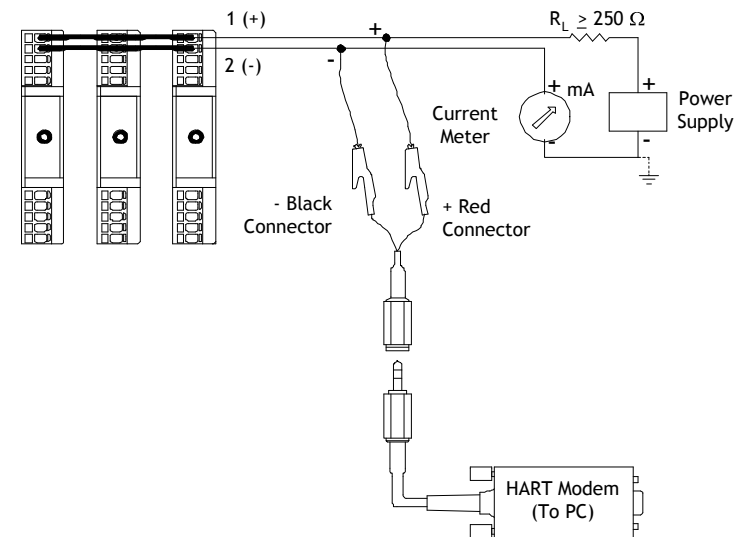


**Fig 3.1b**

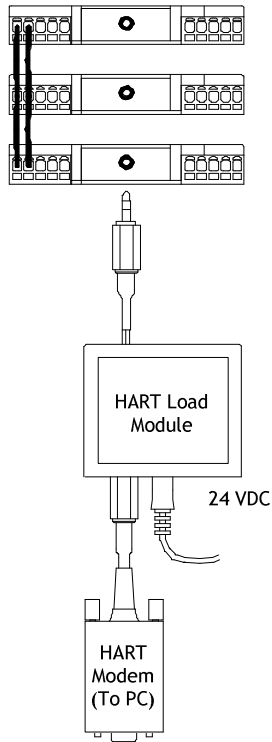


**➤ 4.2 CONNECTION ARRANGEMENTS FOR HART MODEM (e.g. M-CONFIG)**

**Fig 3.2a**



**Fig 3.2b**



Note: Transmitters must be configured individually for Multidrop mode, by setting the Device Number between 1 and 15. This cannot be done while the transmitters are connected together. The SEM315 can also be configured by connecting the Communicator or HART modem across the load in Figure 3.1a and 3.2a respectively

**➤ ALSO AVAILABLE:**

- Smart In Head Temperature Transmitters
- Din Rail Mounted Temperature Transmitters
- Panel & Field Temperature Indicators
- Temperature Probes
- Trip Amplifiers
- Signal Conditioners
- And many other products

For further information on all products:



Status Instruments Ltd, Green Lane Business Park, Tewkesbury, Glos. GL20 8DE  
Tel: +44 (0)1684 296818 ● Fax: +44 (0)1684 293746  
Email: sales@status.co.uk ● Web: www.status.co.uk