



SEM310

HART® IN HEAD TEMPERATURE TRANSMITTER

Status Instruments Ltd, Green Lane Business Park, Tewkesbury, Glos. GL20
8DE

Tel: +44 (0)1684 296818 ● Fax: +44 (0)1684 293746
Email: sales@status.co.uk ● Web: www.status.co.uk

INDEX

SECTION	CONTENTS	PAGE NO.
1.0	DESCRIPTION	1
2.0	SPECIFICATION	1-5
3.0	INSTALLATION	6-7

1.0 DESCRIPTION

The SEM310 is a HART in head temperature transmitter that accepts any commonly used temperature sensor, slidewire transducer or millivolt signal and converts the output to the industry standard (4 to 20) mA transmission signal.

The software package M-CONFIG with a Hart Modem or a Hart Communicator with the necessary "Device Description" can be used to program the unit. Separate instructions are available for programming the transmitter using M-CONFIG.

2.0 SPECIFICATION @ 20 °C

2.1 RTD INPUT (Pt100) 2, 3 OR 4 WIRE

Sensor Range	(-200 to 850) °C (18 to 390) Ω
Minimum Span ¹	25 °C
Linearisation	BS EN60751 (IEC 751) BS 1904 (DIN 43760), JISC 1604, CUSTOM [X] ³
Max Lead Resistance	50 Ω per leg (balanced for 3 wire)
Basic Measurement Accuracy ²	±0.01 % FRI ±0.07 % Rdg (FRI = Full Range Input)
RTD Excitation Current	(300 to 500) µA
Thermal Drift	Zero Span 0.008 °C / °C 0.01 % / °C

2.2 THERMOCOUPLE INPUT

Thermocouple Type	Measuring Range ⁴ °C	Minimum Span ¹ °C
TC Type K	-200 to 1370	50
TC Type J	-200 to 1200	50
TC Type T	-210 to 400	25
TC Type R	-10 to 1760	100
TC Type S	-10 to 1760	100
TC Type E	-200 to 1000	50
TC Type L	-100 to 600	25
TC Type N	-180 to 1300	50
TC Type [X] ³	User defined	

Linearisation	BS EN60584-01 BS 4937/IEC 584-1 (multi segment Polynomials)
Basic Measurement Accuracy ²	0.04 % FRI ±0.04 % RDG or 0.5 °C (whichever is greater)
Thermal Drift	Span 0.01 % / °C
Cold Junction Error	±0.5 °C
Cold Junction Tracking	0.05 °C / °C
Cold Junction Range	(-40 to +85) °C

2.3 MILLIVOLT INPUT

Input Range	Voltage Source (-10 to 75) mV
Characterisation	Linear, Custom [X] ³
Minimum Span	5 mV
Basic Measurement Accuracy ²	±10 µV ±0.07 % Rdg
Input Impedance	10 MΩ
Thermal Drift	Zero Span 0.1 µA / °C 0.01 % / °C

2.4 SLIDEWIRE INPUT

Input Resistance Range	3 Wire potentiometer (10 to 390) Ω (End to End) Larger values can be accommodated by external resistor, see Figure 2.
Characterisation	Linear, Custom [X] ³
Minimum Span ¹	5 % of FRI
Basic Measurement Accuracy ²	0.1 % FRI
Thermal Drift	Zero Span 0.005 % of span / °C 0.01 % / °C
Range	(0 to 100) %

2.5 OUTPUT

Burnout Levels	Low 3.75 mA , High 21.5 mA
Input out of Range	Low 3.8 mA, High 20.5 mA
Output range	(4 to 20) mA, Min. 3.75 mA, Max. 21.5 mA
Accuracy	±5 µA
Thermal Drift	1 µA / °C
Supply Voltage ⁵	(10 to 40) V
Supply Voltage effect	0.2 µA / V
Maximum output load	[(Vsupply-10)/21.5] KΩ 250 Ω minimum loop load for correct HART operation. ⁵

Fig 1

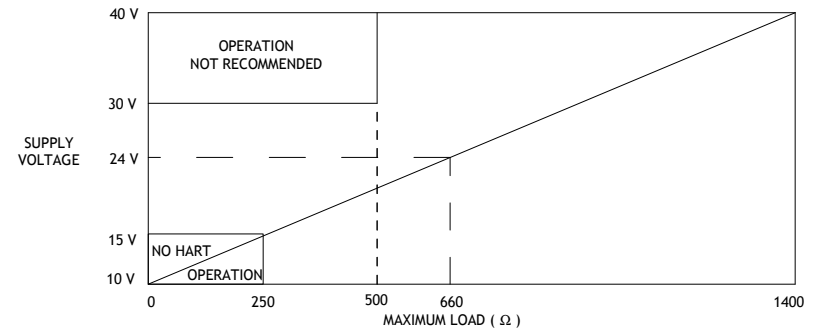

Notes

- 1 Any span may be selected but full accuracy is only guaranteed for spans greater than the minimum recommended.
- 2 Includes the effect of calibration, linearisation and repeatability.
- 3 Custom characterisation is available pre-programmed at the factory. Contact your nearest Sales office.
- 4 Consult Thermocouple reference tables for practical temperature ranges.
- 5 For supply voltages over 30V, a minimum loop load of 500 Ω is necessary.

2.6 GENERAL

Input/Output Isolation	500 VAC (breakdown voltage 3000 VAC)
Time Constant	(Filter Off) 0.5 secs (to 90 % of final value)
Filter Factor Programmable	Off / selectable between 1 and 32 seconds / or Adaptive
Warm-up Time	2 minutes to full accuracy
Re-calibration interval	1 year, to maintain accuracy to published specification. 5 years, to maintain accuracy to less than twice published specification.

ENVIRONMENTAL

Ambient Operating Range	(-40 to 85) °C
Ambient Storage Temperature	(-50 to 90) °C
Ambient Humidity Range	(10 to 95) % RH non condensing

EMC BS EN 61326

MECHANICAL

Enclosure	DIN standard terminal block size
Material	ABS
Weight	43 g
Dimensions	44 mm diameter x 24 mm
Flammability	UL94-V0

2.7 SEM310X VERSION - FOR USE IN POTENTIALLY EXPLOSIVE ATMOSPHERES

2.7.1 ATEX CERTIFICATE

The SEM310X, has been issued with a EC-type examination certificate, confirming compliance with the European ATEX directive 94/9/EC for :-

Intrinsic safety II 1 G EEx ia IIC T4...T6.

The equipment bears the Community Mark and subject to local codes of practice, may be installed in any of the European Economic Area (EEA) member countries. The SEM310X housing is coloured light blue to identify the equipment as suitable for Hazardous area use. The equipment must be installed and maintained in accordance with local requirements for electrical equipment for use in potentially explosive atmospheres, eg EN60079-14 & EN60079-17. This instruction sheet describes installation which conforms with BS EN60079-14 & BS EN60079-17 Electrical Installation in Hazardous Areas. When designing systems outside the UK, the local Code of Practice should be consulted.

2.7.2 ATEX MARKING

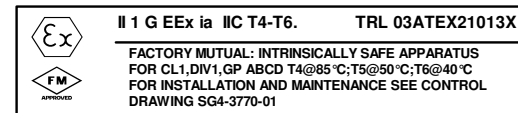
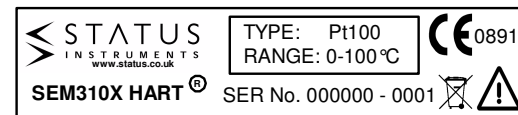

COMMON INFORMATION

Manufacturer Status Instruments Ltd
Type Number SEM310X

CE marking 

Explosive Protection Marking 

(Type ia) Intrinsic Safety

II 1	Equipment Group and category
G	Type of explosive atmosphere (Gas)
EEx ia IIC T4..T6	Intrinsic safety information
TRL03ATEX21013X	Certificate reference

2.7.3 SPECIAL CONDITIONS FOR SAFE

As indicated by the Certificate Reference "X" suffix, special conditions apply for safe use for intrinsic safety applications. They are as follows:-

ZONES, GAS GROUPS, AND T RATING.

When connected to an approved system the SEM310X may be installed in:-

Zone 0	explosive gas air mixture continuously present
Zone 1	explosive gas air mixture likely to occur in normal use
Zone 2	explosive gas air mixture not likely to occur and if it does, it will only occur for a short time.

Be used in gas groups:-

Group A	propane
Group B	ethylene
Group C	hydrogen

Allowable Temperature classification / ambient temperature:-

Intrinsic safety (Type ia)

Class	Ambient Temperature	Range
T1	450 °C	(-40 to 85) °C
T2	300 °C	(-40 to 85) °C
T3	200 °C	(-40 to 85) °C
T4	135 °C	(-40 to 85) °C
T5	100 °C	(-40 to 50) °C
T6	85 °C	(-40 to 40) °C

ENVIRONMENTAL PROTECTION

This equipment must be housed in an enclosure which provides a degree of protection of at least IP54. The enclosure must be suitable for the atmosphere and environment in which it is installed. (eg If of a plastic material, must be resistant to chemical corrosion, UV light, temperature, Humidity, etc).

MAINTENANCE

This intrinsically safe equipment contains no user serviceable, adjustable or replaceable parts. No attempt should be made to repair a faulty SEM310X transmitter, all units must be returned to the manufacture for repair or replacement. Attempting service or replacement of parts may invalidate the explosive protection features of the equipment.

CONNECTION DIAGRAM

They equipment must be electrically connected as shown below:-

Fig 2

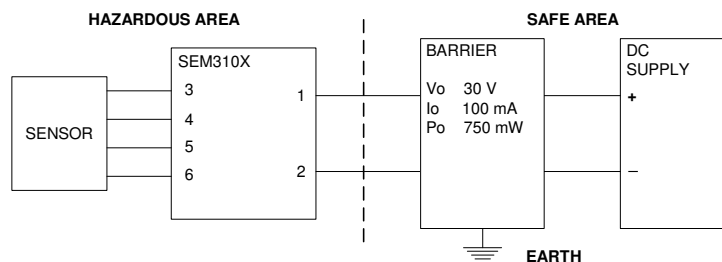

SEM310X Working Parameters

U _i	30 V
I _i	100 mA
P _i	750 mW
C _i	10 nF
L _i	0 H

3.0 INSTALLATION

3.1 MECHANICAL

The transmitter is mounted on standard 33 mm fixing centres and will fit a DIN standard termination head. The transmitter should be installed with adequate protection from moisture and corrosive atmospheres. (Refer to section 2.7.3 Environmental Protection for SEM310X)

A Ø6.3 mm hole is provided through the centre of the transmitter to allow sensor wires to be threaded through the transmitter body direct to the input screw terminals. The screw terminals have been designed to allow all connection wires to enter from an inner or an outer direction.

Care must be taken when locating the transmitter to ensure the ambient temperature remains within the specified operating range.

Fig 3 (All Dimensions in mm)

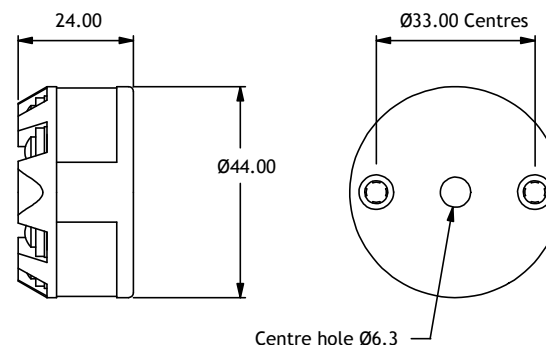

3.2 ELECTRICAL

Connections to the transmitter are made to the screw terminals provided on the top face. No special wires are required for the output connections, but screened twisted pair cable is the most suitable for long runs. It is recommended that screened cable is used for the sensor connection wires for cable runs greater than one metre. All input wires must have the same core diameter to maintain equal lead resistance in each wire.

Figure 4 shows the method of connection to provide a (4 to 20) mA current loop output. The output loop has a voltage power supply used to provide loop excitation. The load symbol represents other equipment in the loop, normally indicators, controllers or loggers. Care must be taken when designing the (4 to 20) mA circuit to ensure that the total voltage requirements of all the equipment in the loop added together, does not exceed the power supply voltage. If a number of instruments are connected in the loop, ensure that only one instrument is tied to ground. Grounding the loop at two points will cause a short circuit of part of the loop leading to measurement errors.

To guarantee CE compliance, sensor leads must be less than 3 metres long and the transmitter housing should prevent access to the transmitter during normal operation.

* Resistance Range, (10 to 390) Ω (End to End) Larger values can be accommodated by fitting 390 Ω resistor (not supplied) as shown below.

(Refer to Fig 2 connection diagram for SEM310X)

Fig 4

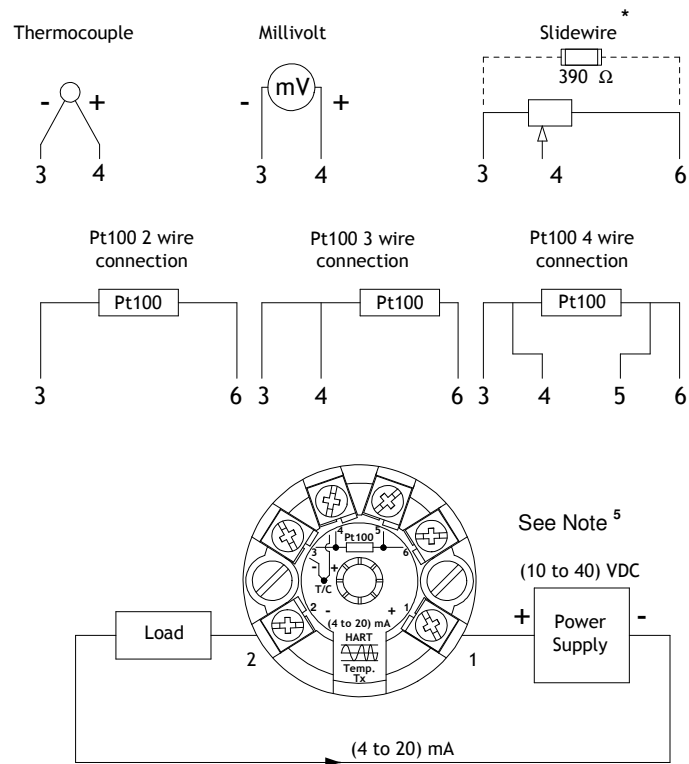

ALSO AVAILABLE:

- Smart In Head Temperature Transmitters
- Din Rail Mounted Temperature Transmitters
- Panel & Field Temperature Indicators
- Temperature Probes
- Trip Amplifiers
- Signal Conditioners
- And many other products

For further information on all products:



Status Instruments Ltd, Green Lane Business Park, Tewkesbury, Glos. GL20 8DE
 Tel: +44 (0)1684 296818 • Fax: +44 (0)1684 293746
 Email: sales@status.co.uk • Web: www.status.co.uk