

161/162 RH/TEMPERATURE SENSOR USER GUIDE

161 with single two wire (4 to 20) mA output.
 162 with dual two wire (4 to 20) mA outputs.
 Optional display.

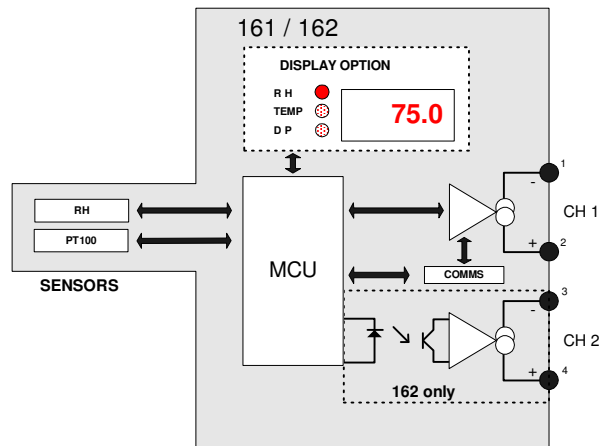

Important - Please read this document before any installing.



Every effort has been taken to ensure the accuracy of this document, however we do not accept responsibility for damage, injury, loss or expense resulting from errors and omissions, and we reserve the right of amendment without notice.



IMPORTANT - CE & SAFETY REQUIREMENTS

Product must be mounted, inside a suitable enclosure providing environmental protection to IP65 or greater.

To maintain CE EMC requirements, input wires must be less than 3 metres.

The product contains no serviceable parts, or internal adjustments. No attempt must be made to repair this product. Faulty units must be returned to supplier for repair.

This product must be installed by a qualified person. All electrical wiring must be carried out in accordance with the appropriate regulations for the place of installation.

Before attempting any electrical connection work, please ensure all supplies are switched off.

ABSOLUTE MAXIMUM OPERATING CONDITIONS (To exceed may cause damage to the unit):-

Supply Voltage	± 30 V dc (Protected for over voltage and reverse connection)
Current with over voltage	± 200 mA
Ambient	Sensor (-35 to 105 °C)
	Electronics (-35 to 85) °C Humidity (10 to 95) % RH (Non condensing)

PRODUCT SPECIFICATION

Please refer to the product data sheet for full specification,

RECEIVE AND UNPACKING

Please inspect the packaging and instrument thoroughly for any signs of transit damage. If the instrument has been damaged, please notify your supplier immediately.

CONFIGURATION



To Configure device use the USB configurator tool available from your supplier. Connect the configurator to the PC USB port, connect Grey / Black wire to terminal 1 and Grey wire to terminal 2.

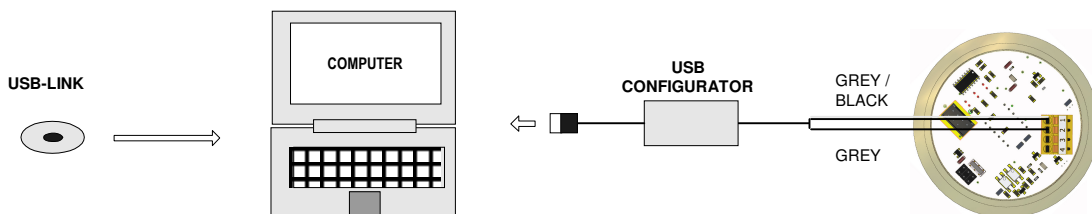

The following parameter can be configured by simply entering as prompted by the software package.

- Tag No
- Install date
- Ch1 (Ch2 162) output type (RH, Ambient, Dew point, Temperature difference in either °C or °F)
- Ch1 (Ch2 162) range
- Two point alignment of both temperature and humidity
- Read live data, set display type on models with display option.

Factory default:

161		
CH1	RH	(0 to 100) %
Alignment	off	
Display option	RH	
162		
CH1	RH	(0 to 100) %
CH2	Tamb	(0 to 50) °C
Alignment	off	
Display option	RH	

MECHANICAL INSTALLATION

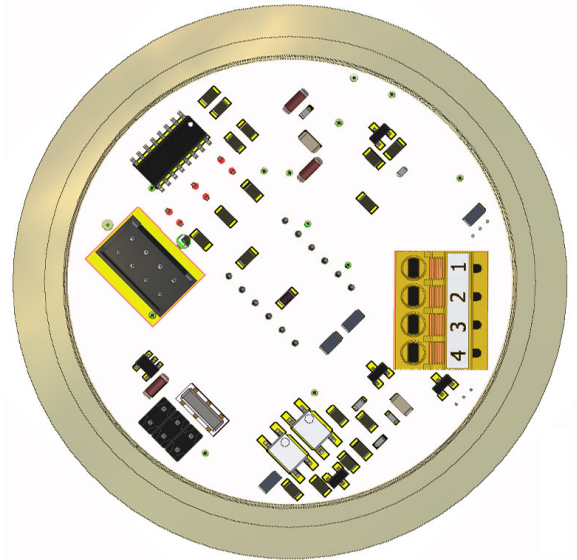
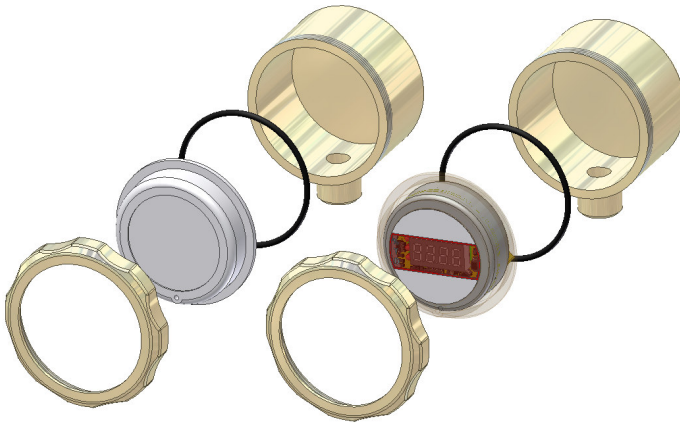

ELECTRICAL INSTALLATION



TURN OFF SUPPLY BEFORE WORKING ON ANY ELECTRICAL CONNECTION

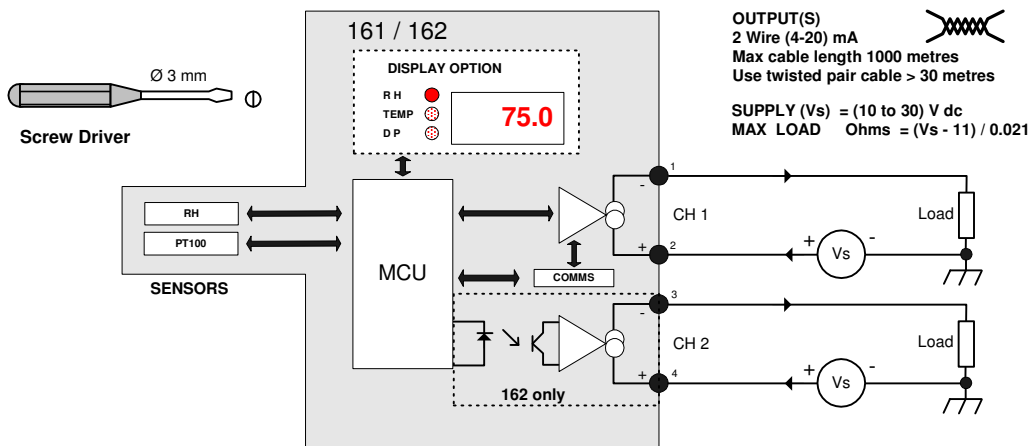

SENSOR

INSTALLATION

Humi-Chip measurement module incorporates an integrated temperature sensor.

The measured values are correct when the Humi-Chip Humidity and Temperature are both in equilibrium with the surrounding ambient conditions.

For optimum performance, the following recommendations must be observed:

- 1) Install the sensor in the most representative location of the ambient to be controlled;
- 2) Avoid direct exposure to sun and atmospheric agents;
- 3) Avoid installing the sensor next to heaters, coolers, steam vents and humidifiers;
- 4) Avoid turbulences which can generate unstable pressures.

Cleaning/replacing the dust filter

The dust filter should be cleaned from time to time depending on the working conditions. Cleaning should be done:

- 1) Removing the filter from the probe as described below (Replacing Humi-Chip module note 1 to 3)
- 2) Then clean it by washing with water or by blowing with compressed air (the filter must be far from the Humi-Chip)

Replacing Humi-Chip

The sensor of the Humi-Chip module does not need any periodic calibration. The replacement sensor is delivered factory calibrated. Calibration is not required after replacement.

If the replacement of the Humi-Chip module is necessary, proceed as follows observing full ESD precautions:

- 1) Switch off the power supply;
- 2) Verify that the Humi-Chip module is at a safe temperature;
- 3) Unscrew the protection filter;
- 4) Gently withdraw the module;
- 5) Insert the new module;
- 6) Re-install the protection filter.

