

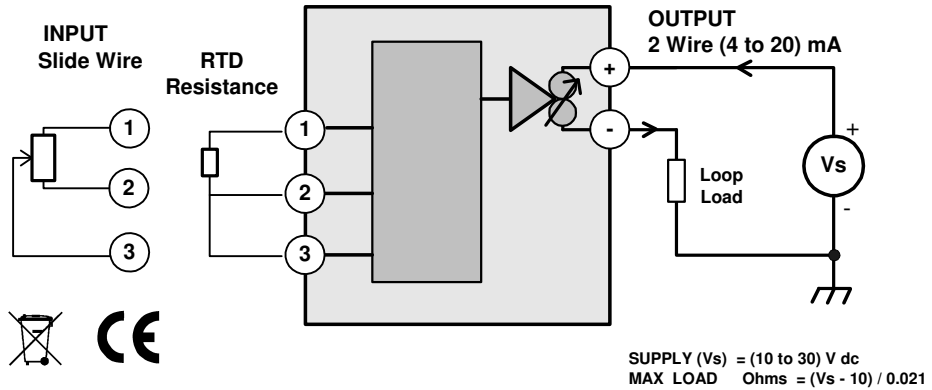

HTR200 / HTR201 USER GUIDE

RTD / resistance or slide wire Input : Two wire (4 to 20) mA output
Important : Read and understand this document before installation.



Description

The product is a cost effective "smart" transmitter head that accepts resistance signals including RTD sensors and converts them to a standard industrial (4 to 20) mA transmission signal over a user programmed range. PC configuration allows the user to select Sensor type, Range, Units and error signal without requiring calibration equipment. Configuration is performed quickly using our new USB port driven configurator by simply connecting to the units loop connector and following the software instructions. Configuration set up may be saved as a file on the PC for later use. Additionally, the user may read live process data when connected to the PC, allowing for sensor offset calibration, where the user can enter an offset value to correct for any sensor offset. Two part screw terminals are provided for sensor and loop wiring.

Important safety Information

To maintain CE compliance all input wires must be less than 3 metres.
The product contains no user serviceable parts, or internal adjustments. No attempt should be made to repair this device. Faulty units must be returned to supplier or manufacturer for repair or replacement.
This product must be installed by competent qualified personnel.
All electrical wiring must be installed to comply with the area standards, regulations.
Before attempting electrical connection ensure all supplies are switched off.
ABSOLUTE MAXIMUM OPERATING CONDITIONS :-

Supply	30 V dc (reverse protected to -30 V dc)
Supply Current on over voltage	+ 100 mA (when supply exceeds 30 V dc protection device will conduct)
Ambient	(-40 to 85) °C

Mechanical Details

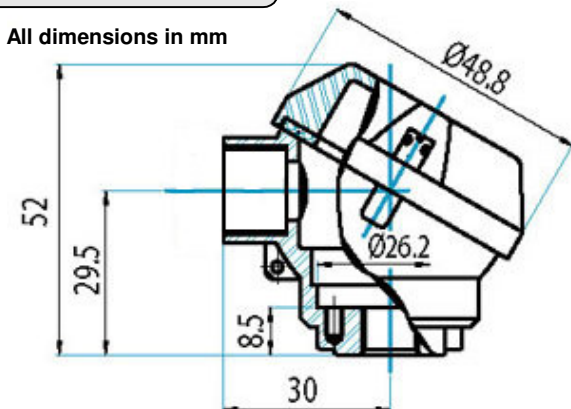

This unit is available with two styles of probe entry, M10 x 1.0 or 1/8" BSP. The unit must be installed with adequate protection from moisture and corrosive atmospheres. The cable entry is M16, the correct type cable gland must be used to match cable size and operating environment and provide protection to at least IP54. Care must be taken with device location to ensure the ambient temperature does not exceed the specified operating temperature.

Enclosure colour - silver.

To gain access to connections un-screw two slotted screws.

Every effort has been taken to ensure the accuracy of this document, however we do not accept responsibility for damage, injury, loss or expense resulting from errors and omissions, and we reserve the right of amendment without notice.

Installation

For the product specification please refer to product data sheet. Installation is normally performed in the following order. If the product has been purchased as part of a probe assembly, steps (1 to 3) will have been completed. The user can re-configure the transmitter range on a completed probe assembly by following from step 1. For advanced user configuration for custom sensors and user linearisation contact technical support at the address overleaf

1. Configuration
2. Probe Assembly
3. Wire Sensor
4. Install Assembly
5. Wire (4 to 20) mA Loop

1. Configuration

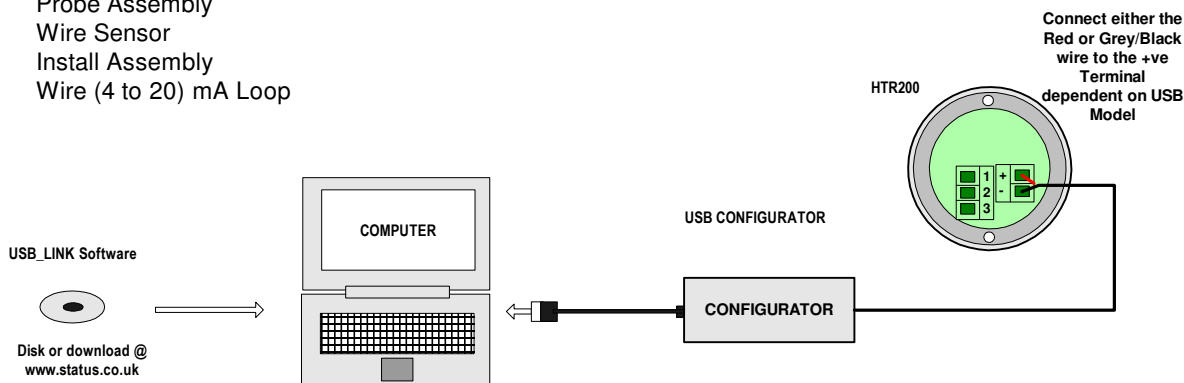

Follow the instructions provided by software menus, refer to the product data sheet for list of configurable parameters.
Factory default PT100 range (0 to 100) °C upscale burnout

2. Probe assembly

The head is available with two styles of probe entry thread M10 x 1.0 or 1/8" BSP. All sensor connections must be isolated from probe sheath.

3. Wire sensor

Sensor connections are made by the use of plug in screw terminals (to maintain BS EN61326 compliance sensor wires must be less than 3 metres) . All sensor connections must be isolated from ground.

Sensor RTD or Resistance (0 to 10.5) Kohm

Slide Wire (1 to 100) Kohm

3 wire

2 wire

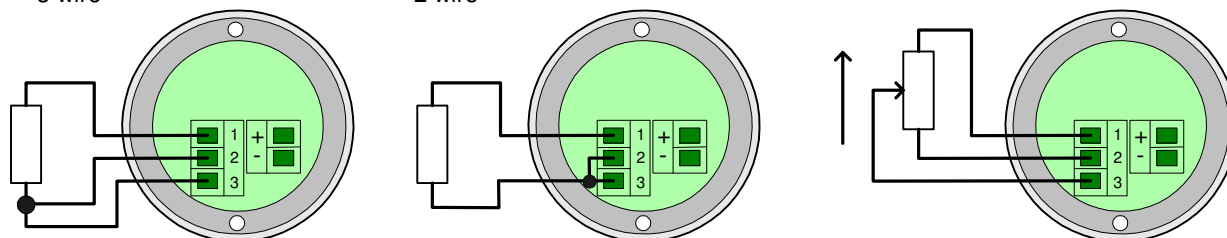

4. Install assembly

Care must be taken as to where the unit is located, so that the ambient temperature of the head does not exceed the specified operating temperature of (-40 to 85) °C

5. Wire (4 to 20) mA Loop

A two way two part connector is supplied for loop connection. Twisted pair or screened cable is recommended for loop wiring. To comply with CE regulations the (4 to 20) mA loop must be earthed at one point, normally at the power supply. The loop load symbol represents other equipment in the loop such as an indicator, controller or signal conditioner.

