



**User instruction for TTC200X electrical apparatus for use in explosion-hazardous area. Important read and understand this document before any installation.**

### ATEX Instructions



For safe installation of the TTC200X in hazardous areas the following instructions must be observed. The transmitter must be installed by competent personnel, who are familiar with national and international laws, directives and standards that apply to their region. For installation in European Economic Area (EEA) member countries users must follow requirements for electrical equipment for use in potentially explosive atmospheres, e.g. EN60079\_14 & EN60079\_17. This instruction sheet describes installation, which conforms with BS EN60079\_14 & BS EN60079-17. Important - Particular attention must be paid the section titled "Special conditions for safe use", failure to comply to this requirement will result in a unsafe system. The TTC200X has been issued with a EC-type examination certificate, confirming compliance with European ATEX directive 94/9/EC for the following specification :-

### Product Information

Following Information is printed on the product label

Manufacturer Status Instruments Ltd  
 Type Number TTC200X  
 Certificate Ref TRAC09ATEX11232X

### Zones

Area Classification		Zone Criteria for Application Atmosphere	
Gases	Dusts		
Zone 0	Zone 20		Present continuously or for long periods (> 1000 hrs per annum)
Zone 1	Zone 21		Likely to occur in normal operation occasionally (> 10 to < 1000 hrs per annum)
Zone 2	Zone 22		Unlikely to occur in normal operation (> 10 hrs per annum)

### Classification

www.status.co.uk  
Made in UK  
**TTC200X**

TYPE: K  
 RANGE: 0-1000 °C

SER No. 000000 - 0001

TRAC09ATEX11232X  
  
 IECEx TRC 10.0008X

0891

II 1 GD  
  
 Ex ia IIC T4 Ga  
  
 Ex iaD 20 T135 °C Da  
  
 Tamb = -20 °C to 85 °C

### Working Parameters

	Terminals	
	+ / -	1 / 2 / 3
Ui =	30 V	1.5 V
Ii =	100 mA	-
Pi =	750 mW	-
Ci =	0	10 nF
Li =	0	0
Uo =	-	5 V
Io =	-	55 mA
Po =	-	0.62 mW

### Additional Information

EMC BS EN 61326-1  
 (Sensor wires max 3Metres to comply.)  
 Enclosure Colour Blue

Every effort has been taken to ensure the accuracy of this document, however we do not accept responsibility for damage, injury, loss or expense resulting from errors and omissions, and we reserve the right of amendment without notice.



Status Instruments Ltd, Green Lane Business Park, Green Lane, Tewkesbury, Gloucestershire, UK, GL20 8DE  
 Web Page: [www.status.co.uk](http://www.status.co.uk) Tel : +44 (0) 1684 296818 Fax: +44 (0) 1684 293746

## Special conditions for safe use



- 1 For gas applications, the TTC200X and TTR 200X temperature transmitters must be mounted in a metallic enclosure rated for IP54 and located in area where the enclosure will not be subject to impact of friction.
- 2 For dust applications, the TTC200X and TTR200X temperature transmitters must be mounted in a suitably ATEX or IECEx certified enclosure appropriate for the zone of end use .
- 3 The equipment shall only be configured by means of the USB connection outside the hazardous area.
- 4 If the equipment is mounted in an enclosure with separate IS circuits, appropriate segregation shall be provided in accordance with IEC 60079-11 Clause 6.2.1.
- 5 TTC200X - Only for connection to suitable thermocouples. These shall conform to the requirements for simple apparatus as defined in IEC 60079-0 clause 5.7 and shall pass a dielectric strength test in accordance with IEC 60079-11 Clause 6.3.12.
- 6 TTR200X - Only suitable for connection to RTD temperature sensors or slide wire resistance devices. They shall conform to the requirements for simple apparatus as defined in EN 60079-0 clause 5.7 and shall pass a dielectric strength test IAW 60079-11 Clause 6.3.12.
- 7 The ambient temperature range of the enclosure will limit the permitted ambient range of the overall equipment. Refer to enclosure certification.

## Maintenance

The appropriate regulations concerning maintenance, repair and testing must be observed. In particular, all parts on which explosion protection depends must be checked during maintenance. The transmitter must never be configured in the hazardous area, the device must be removed and taken to a non hazardous area for configuration.

The enclosure used to house the TTC200X must be cleaned regularly to prevent build up of excessive dust layers.

The TTC200X apparatus contains no user serviceable adjustable, replaceable parts. No attempt should be made to repair a TTC200X device, all units must be returned to the manufacturer for repair or replacement. Attempted service or replacement of parts may invalidate the explosive protection features of the TTC200X.

## Mechanical Detail

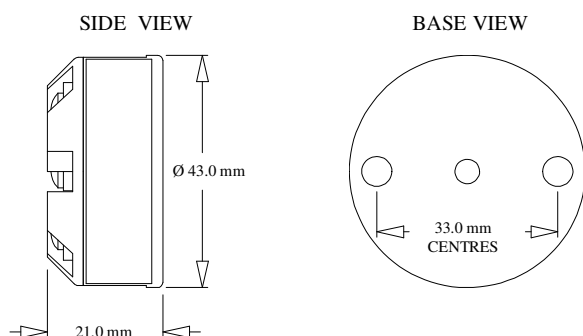

The TTC200X is mounted using two 5.5 mm holes, on standard 33 mm fixing centres and will fit a DIN standard termination head. The TTC200X must be installed with adequate protection from moisture and corrosive atmospheres. Refer to "special conditions for safe use" section of this user guide for information on enclosure IP rating.

Care must be taken to ensure the TTC200X is located to ensure the ambient temperature does not exceed the specified operating temperature as specified in the "TEMPERATURE CLASS" table.

## Electrical Detail



REFER TO CONDITIONS FOR SAFE USE

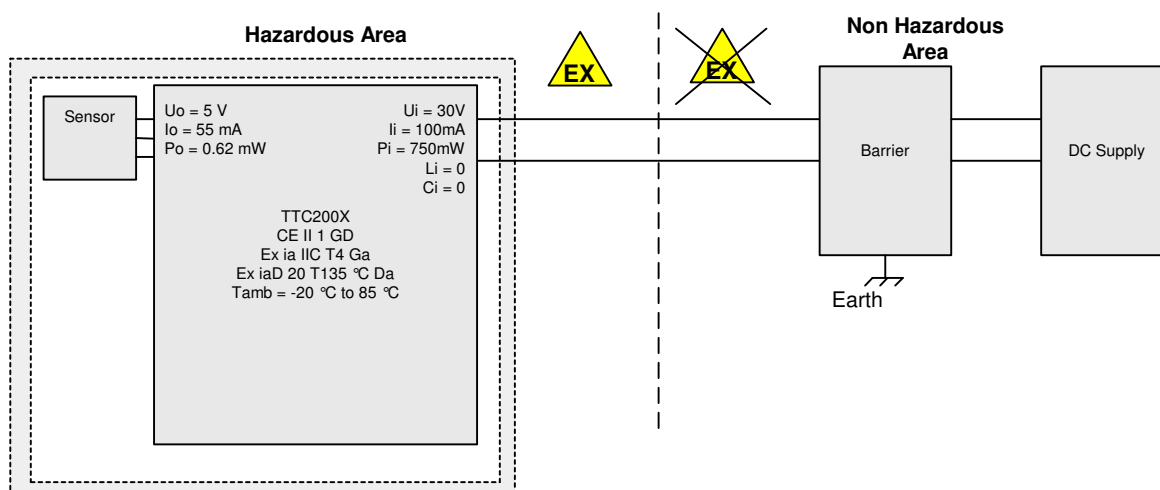

## Installation



REFER TO CONDITIONS FOR SAFE USE

For TTC200X specification please refer to product data sheet. Installation is normally performed in the following order. If the TTC200X has been purchased as part of a probe assembly, steps (1 to 3) will have been completed. The user may wish to reconfigure the transmitter range, in this instance the TTC200X range can be changed on a completed probe assembly by following step 1.

1. Configuration
2. Mount Transmitter into head
3. Wire Sensor
4. Install Assembly
5. Wire (4-20) mA Loop

### 1. Configuration

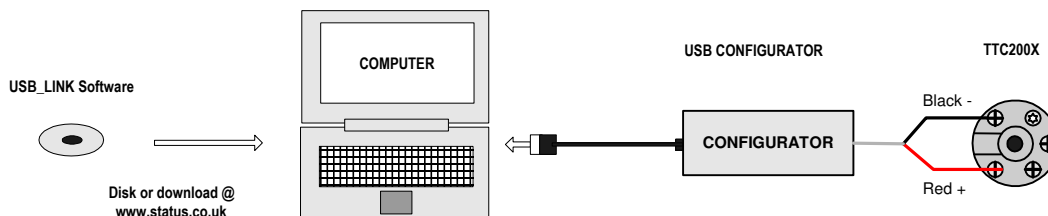

Follow the instructions provided by software menus, refer to TTR200X data sheet for list of configurable parameters.  
Factory default Type K range (0 to 1000) °C upscale burnout

### 2. Mount Transmitter into Head

The TTC200X is mounted using two 5.5 mm holes, on standard 33 mm fixing centres and will fit a DIN standard termination head. The TTC200X must be installed with adequate protection from moisture and corrosive atmospheres. Refer to "special conditions for safe use" section of this user guide for information on enclosure IP rating. A centre hole is provided in the TTC200X case, this allows for sensor wire to enter wiring section through the TTC200X body. Observe the "special conditions for safe use" instruction.

### 3. Wire sensor.

Sensor connections are as follows, to maintain BS EN61326 compliance sensor wires must be less than 3 metres. Ensure the correct compensation cable is used for input connection. The input is galvanically isolated from the output.

Thermocouple sensor connection

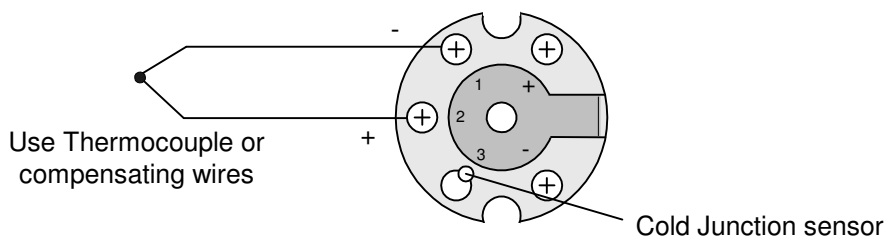

### 4. Install assembly

Care must be taken to ensure the TTC200X is located to ensure the ambient temperature does not exceed the specified operating temperature as specified in the "TEMPERATURE CLASS" table.

### 5. Wire (4 to 20) mA Loop

Ensure all other aspects of the installation comply with the requirements of this document, paying particular attention to the loop barrier. The (4 to 20) mA loop is connected as follows:-

