

SMART RTD (SLIDE WIRE, RESISTANCE) HEAD VOLTAGE TRANSMITTER

HTR200V/HTR201V

- **MAA TYPE ALUMINIUM HEAD WITH INTEGRAL TRANSMITTER**
- **60% LIGHTER THAN A CONVENTIONAL TRANSMITTER AND HEAD**
- **52mm SWING DIAMETER**
- **INPUT: RTD, SLIDEWIRE, RESISTANCE**
- **THREE WIRE VOLTAGE OUTPUT WITH USER ADJUSTABLE RANGE**
- **USER LINEARISATION**
- **PC PROGRAMMABLE**



INTRODUCTION

The HTR200/V is a cost effective “smart” transmitter integrated into an MAA type connection head that accepts resistance signals including RTD sensors and converts them to a programmable voltage output of any value between 0 and 10 VDC. There are two versions available with either 1/8” BSP or M10 x 1.0 probe connections. Its small size (52mm swing diameter), allows for installations where space is critical and being 60% lighter than a conventional transmitter installed in a KNE type alloy head, means smaller stem diameter and head threads can be used in the temperature probe. Temperature probes are sold separately and our style 1 and 2 are the most popular with this product.

A flexible approach has been taken with this design in that, the standard product will accept over 30 resistance sensors, including Pt100, Pt500 Pt1000, Ni100, Ni1000 and variable resistance. The new design also allows for custom sensors to be accommodated. It is also possible to generate your own linearisation curve for resistance or slide wire inputs. For further information, please contact the Sales Office.

PC configuration allows the user to select Sensor type, Range, Units and error signal without requiring calibration equipment. Configuration is performed quickly using our USB port driven configurator by simply connecting two clips to the HTR200/V power terminals and following the software instructions. Additionally, the user may read live process data when connected to the PC, allowing for sensor offset calibration, where the user can enter an offset value to correct for any sensor offset.

If required, the desired range can be specified at the time of order, removing the need for user configuration. If the range is not specified then the transmitter will be shipped with the default range of Pt100 (0 to 100) °C and output of (0 to 10) VDC.

PC CONFIGURATION

EQUIPMENT

COMPUTER	Running Windows XP or later with USB port
USB CONFIG KIT	Comprising: USB Configurator with connecting leads
USB Link S/W	Available as a free download at www.status.co.uk

METHOD

- Load PC with USB_LINK software.
- Connect USB Configurator to PC USB port.
- Connect Tool clips to HTR200_V Power Terminals Red (+)
Black (-)
- Run software, set configuration required and save to device.

SPECIFICATIONS @ 20 °C

INPUT

Sensor Connection	2 or 3 wire Screw terminal
Minimum span	25 °C
Thermal Drift	0.0025 % / °C
Excitation current	<200 uA
Lead Resistance effect	0.002 °C / Ohms
Maximum lead Resistance	20 Ohms per leg

OUTPUT

Output Type	Three wire Voltage
Output range	Selectable within (0 to 10) Volts
Current Drive	2 mA Max
Output Connection	Screw Terminal
Output Limits	(-0.1 to 10.5) Volts
Accuracy	(Voltage output /1000) or 5 mV (Whichever is the greater)

Thermal drift	1 mV / °C
Minimum output load	5000 Ω

GENERAL SPECIFICATION

Update time	200 ms
Response Time	0.5 seconds
Start up time	1 seconds (Vout 0.0 V during start up)
Power Supply	(12 to 30) Volts dc
Warm-up Time	1 Minute

SMART RTD (SLIDE WIRE, RESISTANCE) HEAD VOLTAGE TRANSMITTER

INPUT TYPES (see note *1 and *4)

PROCESS SENSORS

Sensor	Range (°C)	Accuracy
Pt100 IEC 0.003851	-200 to 850	± 0.2°C + (±0.05% of rdg) (*2)
Pt100 IPTS-68 0.00391	-200 to 630	
Pt100 IPTS-68 0.00392		
Ni 100 DIN 0.00618	-60 to 180	
Ni 120 0.00672	-80 to 260	
Cu 100 0.00427		
Cu 53	-50 to 180	

BMS/HVAC SENSORS

Pt 1000 IEC	-200 to 600	± 0.2°C + (±0.05% of rdg) (*2)
Pt 500 IEC	-200 to 750	
Ni 1000	-60 to 180	
Ni 1000 TK5000	-50 to 150	
Cu 1000	-80 to 260	
Ni 507.5	-80 to 360	
Ni 604	-200 to 200	

BMS/HVAC SILICON SENSORS

KTY81-110 KTY81-120 KTY81-150 KTY82-110 KTY82-120 KTY82-150	-55 TO 150	± 0.2°C + (±0.05% of rdg) (*2)
KTY81-121 KTY82-121		
KTY81-122 KTY82-122		
KTY81-210 KTY81-220 KTY81-250 KTY82-210 KTY82-220 KTY82-250		
KTY81-221 KTY82-221		
KTY81-222 KTY82-222		
KTY81-151 KTY82-151		
KTY83-210 KTY83-220 KTY83-250	-55 TO 175	
KTY83-121		
KTY83-122		
KTY84-130 KTY84-150	-40 TO 300	
KTY84-151		

SLIDE WIRE

Pot Value 1 KΩ to 100 KΩ *3	0 to 100%	0.05% (*2)
-----------------------------	-----------	------------

RESISTANCE

10 Ω to 10450 Ω	(10 to 500) Ω ± 0.055 Ω (500 to 2500) Ω ± 0.5 Ω (2500 to 10450) Ω ± 10.0 Ω (*2)
-----------------	------------------------------------------------------------------------------------------

ENVIRONMENTAL

Ambient operating range (-40 to +85) °C
 Ambient storage temperature (-50 to +90) °C
 Ambient humidity range (10 to 90) % RH non condensing

PHYSICAL

Dimensions 52 mm Swing diameter, 52 mm Height
 Weight 90 g max

APPROVALS

EMC - BS EN 61326

ANNEX A

ANNEX F

IEC 61000-4-2
 IEC 61000-4-3
 IEC 61000-4-4
 IEC 61000-4-5

Electrical equipment for measurement control and laboratory use.
 Immunity test requirements for equipment intended for use in industrial locations
 Test configurations, operational conditions and performance criteria for transducers with integrated or remote signal conditioning.
 Electrostatic discharge
 EM Field
 Transient Burst (output)
 Surge (output)

Note - Sensor input wires to be less than 3 metres to comply.

Note *1

Any span may be selected, full accuracy is only guaranteed for spans greater than the minimum recommended

Note *2

Basic measurement accuracy includes the effects of calibration, linearisation and repeatability

Note *3

Slide wire end to end resistance, range (0 to 100)% represent end to end travel

Note *4

Data files for °F and Kelvin ranges available by contacting the Sales Office

MECHANICAL

All Dimensions in mm

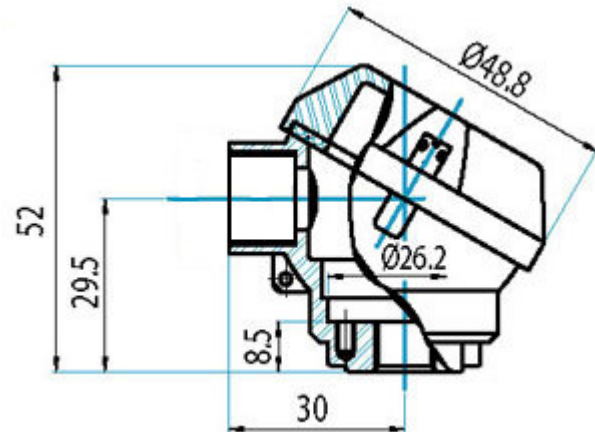

ORDER CODE

HTR200V Probe entry M10 x 1.0
 HTR201V Probe entry 1/8" BSP

Accessories:
 USB Config Kit
 M16 Metal Gland

See our Data Sheet for suitable probes