

6.0 WIRING DIAGRAM

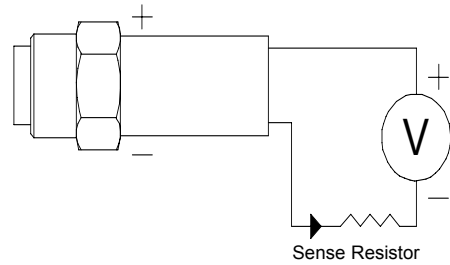

7.0 MECHANICAL / CONNECTION DETAIL

7.1 PTX21 - DIN Connection Detail

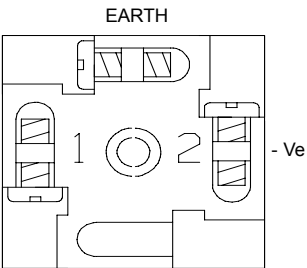
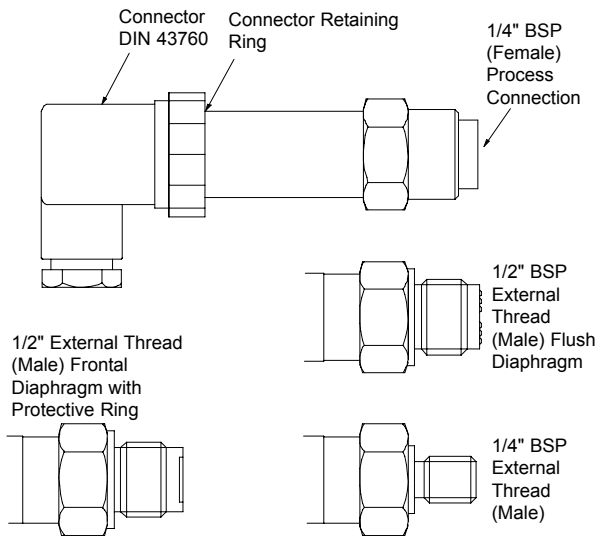

PTX21 Connection Details

The PTX21 "Earth" is connected to the body of the transmitter. If the body is connected to earth, it is not necessary to connect this pin.

7.2 PTX21 Span / Zero Settings (See 5.2)

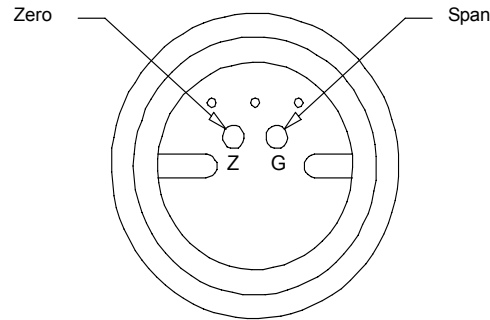

7.3 PTX24 - Connection Head Version

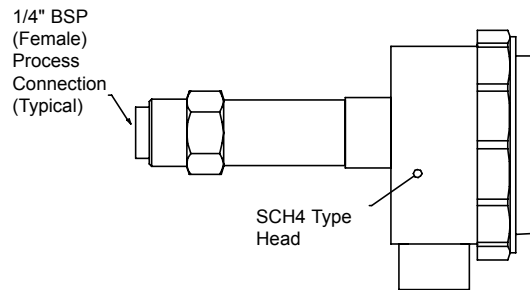

Other process fittings are available.

7.4 PTX24 Connection Details, Span / Zero Settings (See 5.2)

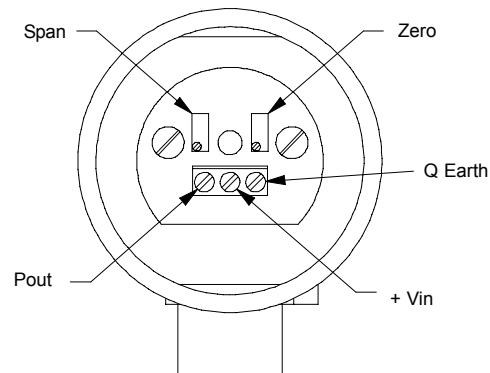

PTX 21 & PTX 24 PRESSURE TRANSMITTERS (INSTALLATION GUIDE)

Designed, manufactured and supported by :



Green Lane
Tewkesbury, Gloucestershire
GL20 8DE. UK
Telephone : 01684 296818
Fax : 01684 293746
Email: support@status.co.uk

Every effort has been taken to ensure the accuracy of this specification, however we do not accept responsibility for damage, injury, loss or expense resulting from errors and omissions, and we reserve the right of amendment without notice.

Stock code : 52-414-2161-01

Issue : 01

1.0 RECEIVING & UNPACKING

THIS PACKAGE CONTAINS DELICATE MEASUREMENT EQUIPMENT THAT REQUIRES CAREFUL HANDLING

Pressure transmitters are packed individually using suitable packing material which affords excellent protection for normal handling.

1. The external condition of the carton should be noted, with particular attention for signs of damage from impact or puncture.
2. When the goods are opened for inspection, ensure that the Operating Instructions and Calibration Certificate (if requested) are not accidentally lost or destroyed.
3. Open the box to expose the transmitter including the electronics (and any other accessories if applicable).
4. If the product has been specified for service with a critical media requiring special cleaning, the outer protection should not be removed unless under conditions of controlled cleanliness.
5. All products are supplied in a calibrated condition. Do not change any instrument settings when undertaking an examination for damage in transit.
6. Do not touch, blow down or press against the measurement diaphragm as this can cause irreparable damage.

2.0 SPECIFICATION

2.1 Input

Pressure Range	Standard DIN Pressure Ranges 0-100 mBar to 0-600 Bar full scale
Over Pressure	The rated pressures can be exceeded to the following limits without degrading performance: 3xFS 0 mbar to 2 bar (min 3 bar) 3xFS >2 to 25 bar 3xFS >25 to 600 bar (850 maximum)
Burst Pressure	>200 bar for ranges to 25 bar >850 bar maximum 25 to 600 bar
Supply Voltage	4-20mA 9 to 33 VDC
Voltage Influence	<0.1% FS
Load Resistance	Supply-9V / 0.02A
Load Influence	< 0.1% FS
Output Signal	2 Wire, 4-20mA

2.2 Output

Operating Temp Range	Standard 0°C to +70°C (medium (0 to 80°C))
Option	-25°C to + 85°C (-25 to 100°C) -25°C to + 85°C (-25 to 150°C)
Accuracy	Combined Non-Linearity, Hysteresis and Repeatability not deviate from the straight line connecting Zero and FS output by more than 0.5% FS.
Option	±0.25% FS version <0.1% FS
Process Compatibility	Fluids compatible with a fully welded assembly of stainless steel and viton seal <25 Bar 304 SS >25 Bar 316Ti SS
Long Term Stability	0.2% FS 0.1 to 2 bar 0.2% FS 2 bar to 1000 bar

2.3 Approvals

EMC	Emissions EN50081 Immunity EN50082 Optional EN61000-4-5 Surge (lightening strikes)
Hazardous Area	The PTX21X is I.S. approved to EEx ia IIC T3 to T6

3.0 INSTALLATION

(For connection details see sections 6 & 7)

The installation should be undertaken in accordance with BS6739 - British Standard Code of practice for "Instrumentation in Process Control Systems : Installation Design and Practice."

All Status Instruments Ltd transmitters are designed to withstand conditions normally found in process applications, however for maximum life and ease of maintenance the following guidelines should be observed.

1. Prior to installation, ensure the pressure source is not under pressure.
2. Avoid installing the pressure sensor in close proximity to motors, pumps, valves and heat sources. Excessive vibration or pressure peaks may falsify the sensor readings or even damage the sensor.
3. In most cases, the equipment is shipped with a protective cap remove the cover and tighten the sensor assembly with a torque of 35Nm.
4. Use screened vented cable with the screen connected to earth at one end only.
5. Maximum supply voltage should not exceed 33V DC I.S.

4.0 INITIAL COMMISSIONING

The instrument is supplied factory calibrated and requires no further adjustment for the majority of applications.

5.0 CALIBRATION

In normal operation, calibration checks should be made on a regular basis to ensure the accuracy of the transmitter system.

The recommended re-calibration interval is 1 year.

5.1 Equipment Required

In order to calibrate the transmitter to the accuracy limits obtained during factory calibration the following equipment is required :

- a. A pressure source to cover the required sensor range traceable to national standards with an accuracy of better than ±0.03% of reading with adapters to couple the pressure source to the transmitter to be calibrated.
- b. A current measurement device with a resolution of at least 0.01mA and an absolute accuracy traceable to national standards of better than ±0.005mA over the measurement range of 4.00mA to 20.00mA.
- c. A 24VDC Nominal, power supply. If the measurement equipment used is of lower accuracy than the limits stated above, differences between the factory calibration data and the subsequent re-calibration data may be noted.

5.2 Calibration Procedure

- 1a. (PTX21) Remove connector retaining ring and connector end plug to expose span and zero potentiometers (see 7.2).
- 1b. (PTX24) Remove cap retaining ring (see 7.4).
2. Connect calibration equipment.
3. With no pressure applied use zero pot to adjust output to 4.000mA.
4. Apply full scale pressure and measure the output current I_o in mA.
5. Calculate scale error factor (Se) as follows:
 $Se = 16 / (I_o - 4)$.
6. Calculate zero error (Ze) as follows:
 $Ze = (Se - 1) \times 0.6$
7. Adjust span pot until current reads $(20 + Ze)$ mA.
8. Remove pressure and re-adjust zero pot until current reads 4.000mA.
9. Re-check full scale pressure and if necessary repeat procedure.

- **Note:** Small changes in zero to compensate for installation errors may be made without affecting Span. In this instance **DO NOT ADJUST** span control as full re-calibration will be required.