

1.0 DESCRIPTION

The low temperature version is suitable for monitoring in ducts or onto a flat surface and operates in the temperature range -25 to +80°C and 0-100% RH (see section 3.0 for full specification).

The high temperature version is a stainless steel bodied probe that operates over the temperature range -30 to +140°C and 0-100% RH.

Two wire loop powered operation provides good noise immunity and economic site wiring. Connection of the site wiring to the transmitter is via plug in screw terminals which are removable from the PCB for ease of wiring.

The sensor is fitted with a PTFE membrane filter around the sensor guard body, to remove harmful dust and other airborne pollutants whilst allowing the moisture vapours to enter the sensing area of the probe. The probe **MUST NOT** be operated without this filter in place.

WARNING: PLEASE READ THESE INSTRUCTIONS CAREFULLY BEFORE ATTEMPTING TO INSTALL THIS TRANSMITTER.

2.0 HANDLING

Handle the probe with care during installation, the sensing element used to measure the humidity is of glass construction. Although mechanically robust when permanently fixed into position, it may be damaged if the probe is dropped or shocked in any way.

Sensor probes should not be mounted in positions in which they will be exposed to moisture contact e.g. rain. Units being mounted outdoors should be fitted into suitable protective enclosures with an adequate air movement.

Sensors should not be exposed to humidity and temperature levels outside their specified operating ranges.

3.0 SPECIFICATION

Approvals

EMC Emissions	BS EN 50081
Susceptibility	BS EN 50082

Mechanical Details

Sensor filter	PTFE Sub-micronic (Field replaceable)
Protection (Head)	IP65 enclosure
Connections	Removable screw terminals
Maximum wire size:	2.5mm ²
Recommended cable diameter:	4-8mm ²
Cable entry:	Compression type cable gland to IP65

Note: The humidity sensor element may be damaged if it becomes contaminated, the product warranty excludes the sensor element.

3.1 Low Temperature Version

Relative Humidity

Sensor	Capacitive	
	3% Version	2% Version
Nominal Operating Range (Sensor)	20-95% RH	5-98% RH
	-40 to +40°C	-40 to +60°C
Extended Range (Temperature <80°C)	<50%RH	<75%RH
Accuracy	±3%	±2%
Hysteresis	<3%	<1%

Response time	10% to 90% RH - less than 15 secs for 90% of step change
Linearity	5% to 95% ±1.5% RH
Output:	4-20mA 2 wire for 0-100°C

Temperature (when fitted)

Sensor	Pt100
Accuracy	0.3°C @ 0°C
Output:	4-20mA 2 wire for 0-50°C

General

Ambient Operating Range) (Electronics Head)	(-20°C to +55°C (5-95% non-condensing
Supply voltage	10 - 30V DC

3.2 High Temperature Version

Relative Humidity

Sensor	Capacitive
Nominal Operating Range (Sensor)	0-100% RH, -30°C to +140°C
Operating Range for Full Accuracy	11-90%RH, -20°C to +70°C
	Accuracy ±2.5%

Extended Range (Temp.<120°C)	<15%RH
Hysteresis	<1%
Response time	10% to 75% RH - less than 10 secs for 90% of step change
Output:	4-20mA 2 wire = 0-100%RH

Temperature

Sensor:	Pt100
Accuracy:	±0.3°C at 0°C
Output:	4-20mA 2 wire for 0-100°C

General

Ambient Operating Range) (Electronics Head)	(-20°C to +55°C (5-95% non-condensing
Supply Voltage:	10-30V DC (Nominal 24V)
Output load (maximum)	(V supply - 10) / 20 (k ohms)

4.0 INSTALLATION

It is recommended that transmitters are not fitted into an installation until after the air distribution system has been running for an initial period of at least several hours. This will permit the system to clear itself of contaminants and reduce the possibility of sensor contamination.

4.1.1 Low Temperature, Duct Mount Versions

WARNING: If duct temperatures are likely to exceed 50°C a "stand off" mounting should be used to avoid exceeding the rated temperatures of the electronic assembly.

Cut a 27mm diameter hole in the chosen position of the duct wall to allow the probe to enter the duct. Make sure the probe does not foul the opposite wall of the duct. Position the probe shaft through the 27mm aperture to its full extent and with the cable gland of the electronics housing in the vertical downwards position, note and mark the two fixing slots at the side of this housing. The fixing slots are moulded at an angle to facilitate easier screwdriver access.

4.1.2 Low Temperature, Wall Mount Versions

Position the transmitter at the desired location with the sensor stem either horizontal or pointing downwards mid way between floor and ceiling. Avoid the following locations :-

- Near to entrances, exits or windows
- In direct sunlight or near room heating devices
- In direct line of air conditioning vents

Remove the probe and drill the two marked positions to receive No.6 x 19.1mm self-tapping screws. As a guide, in soft materials i.e. aluminium, plastics, wood etc. a 2.5mm drill is recommended. In harder and/or thicker materials use a 3mm drill.

On duct mount devices, the neoprene compression ring, between the housing and the duct, will give a good degree of sealing when the probe is fixed as recommended.

4.1.3 High Temperature Version

The high temperature version is supplied with a ¼" BSP compression fitting, which should be fixed to a suitable adaptor plate for mounting.

4.2 WIRING

The electronic housing contains the wiring terminals which are screw type clamps. A maximum core size of 2.5mm² can be accepted, with an overall cable diameter of between 4 and 8mm. Pass the cable through the cable gland of the probe and connect to the relevant terminals using small loops for each core to reduce strain on the PCB mountings. The connecting terminals are removable from the PCB for ease of wiring (see diagram in section 4.3).

4.3 ELECTRICAL

Connections are made to the two 2 way terminal blocks on the transmitter PCB as shown in diagram below :

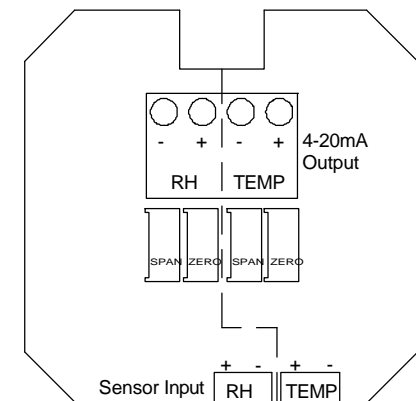

Both relative humidity and temperature channels require DC supplies in the range of 12 to 32 volts (nominal 24 volts).

Temperature connection unavailable on "humidity only" versions.

5.0 CHANGING THE FILTER

5.1.1 Low Temperature Version Only

Remove protection cage from the probe stem (as shown below), by applying steady upward pressure to the sensor cage. Remove and discard old PTFE filter.

Use a high grade 12mm wide PTFE tape, lay onto a piece of paper to reduce the static effect, cut off a 50mm length. The PTFE tape is now fitted to the PTFE membrane to cover the sensor guard holes. Apply light pressure, rubbing the tape in the direction of the tape end joint. Refit the sensor cage after the operation.

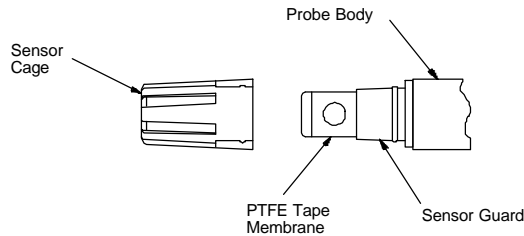

5.1.2 High Temperature Version Only

Remove filter retaining spring. Remove old filter tape, replace with a 40mm length of PTFE tape using method described in 5.1.1, Refit retaining spring.

6.0 CALIBRATION CHECK FOR HUMIDITY (%RH)

The probe may be checked for correct operation if the need arises (calibration capsules are required). Check capsules are available.

With power applied to the probe affix the lowest value of capsule over the sensor cage, leave for 60 minutes minimum then check the %RH 4-20mA output using a current meter. Adjust humidity ZERO pot if required.

Note: The reading should be $\text{Capsule Value (\%RH)} \times 16\text{mA} + 4\text{mA}$

Replace low value capsule for a high value capsule, leave for 30 minutes and check the %RH output signal. Adjust the humidity SPAN pot if required, repeat process until unit is within specification. Remove power from the probe, disconnect meter, refit the probe into position.

6.1 Calibration Check For Temperature °C

To check the calibration of the temperature, the probe should be compared with a reference probe within a stable environment. Slight inaccuracies can be corrected by adjusting the temperature zero pot. If greater inaccuracies have occurred the unit should be sent back for re-calibration.

7.0 MECHANICAL

7.1 Low Temperature Duct Mount Versions

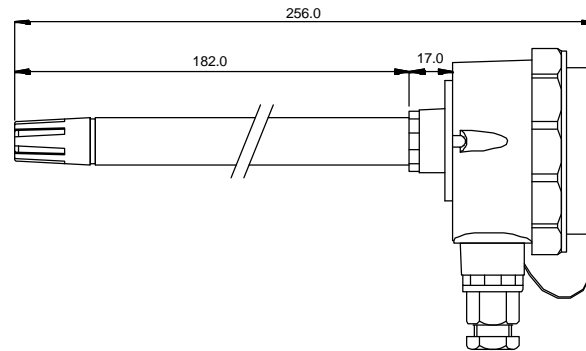

7.2 Low Temperature Wall Mount Versions

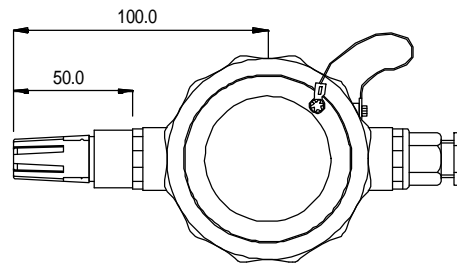

7.3 High Temperature Version

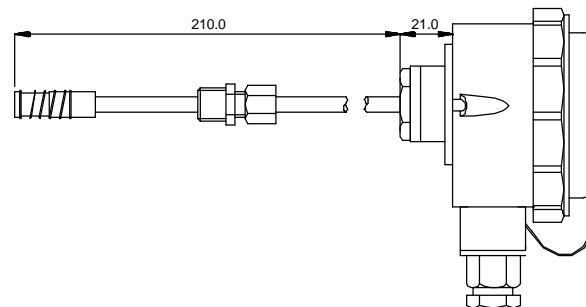

HUMIDITY & TEMPERATURE TRANSMITTER

Every effort has been taken to ensure the accuracy of this specification, however we do not accept responsibility for damage, injury, loss or expense resulting from errors and omissions, and we reserve the right of amendment without notice.

Stock code : 52-214-2259-01

Issue : 01