

DM660P Precision Battery Powered Digital Thermometer User Guide

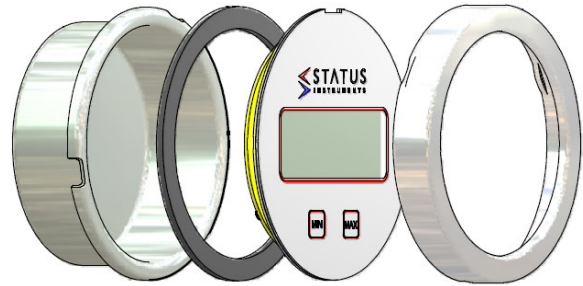

Important - Please read this document before any installing.

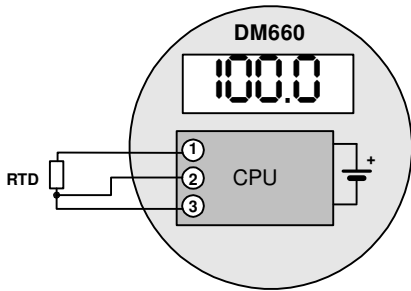

Every effort has been taken to ensure the accuracy of this document, however we do not accept responsibility for damage, injury, loss or expense resulting from errors and omissions, and we reserve the right of amendment without notice.



IMPORTANT - CE & SAFETY REQUIREMENTS

- Product must be mounted, inside a suitable enclosure providing environmental protection to IP65 or greater.
- To maintain CE EMC requirements , input wires must be less than 3 metres.
- Apart from the battery the product contains no serviceable parts. No attempt must be made to repair this product. Faulty units must be returned to supplier for repair.
- This product must be installed by a qualified person. All electrical wiring must be carried out in accordance with the appropriate regulations for the place of installation.
- Battery - Fire Explosion and Severe Burn Hazard . Do not attempt to re-charge, Crush, Incinerate, Disassemble, Heat above 100 °C (212 °F) or expose to water.
- Disposal of the battery must conform with the regulations applicable for the area use.

ABSOLUTE MAXIMUM CONDITIONS (To exceed may cause damage to the unit):-

Battery Voltage	+ 3.7 V dc (Protected for reverse connection)
Input Voltage	± 1 V between any terminals
Ambient	Temperature (-10 to 50) °C Humidity (10 to 95) % RH (Non condensing)

PRODUCT SPECIFICATION

Please refer to the product data sheet for full specification, available to download at www.status.co.uk.

RECEIVE AND UNPACKING

Please inspect the packaging and instrument thoroughly for any signs of transit damage. If the instrument has been damaged, please notify your supplier immediately.

CONFIGURATION AND BATTERY REPLACEMENT



IMPORTANT Always remove battery before any configuration changes or wiring takes place. Gain access to user adjustment and battery holder by twisting cap to release front panel assembly from case.

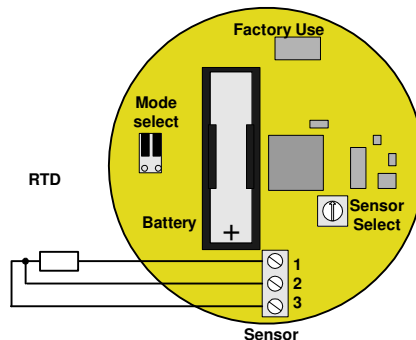
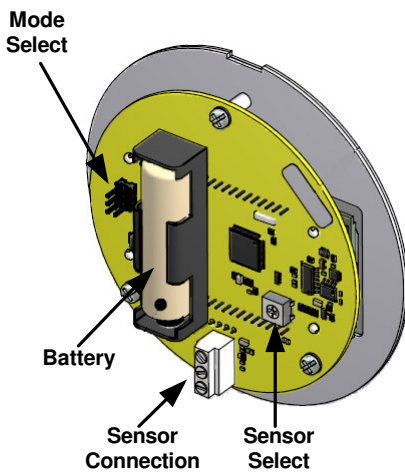

Mode select

A 6 pin jumper is used to select °C or °F run modes. (°C and °F cal selection is also provided for user calibration)



°C Run mode



°F Run mode

Sensor select

Rotary Switch Settings- 16 position hexadecimal switch is used to select the sensor types as follows (Note not all positions are used):-

Position	0	PT100 - 0.003851 (IEC)	Position	4	PT100 - 0.00393 (ITS-90)
	1	Ni120 - 0.672 Nickel A		5	Cu100 - 0.00427
	2	PT100 - 0.00391 (IPTS-68)		6	Ni100 - 0.00618 (DIN)
	3	PT100 - 0.00392 (IPTS-68)		7	Cu53

Sensor Connect

Connect sensor to screw terminals 1 to 3 as shown (for 2 wire sensors link terminals 2 and 3) To comply with the CE regulations sensor lead must be < 3 M.

Battery

Please observe the above battery warnings. To remove battery use screw driver to ease the positive end of battery out of holder. Insert new battery negative end first then press into place. (Observe polarity). Battery type 3.6 V Lithium (2.4 A/HR) CR14505 (IEC) AA case style.

MECHANICAL INSTALLATION

Case Styles - Note wall mounted versions are retained through three 4.5mm Dia holes



Style A Side Entry



Style B wall mount

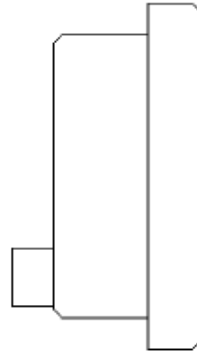

Style C Rear Entry

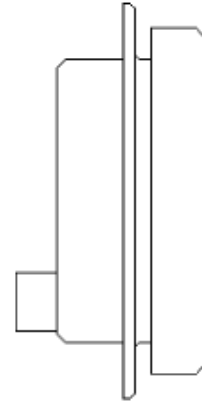

Style D Panel Mount

The enclosure must be sealed to at least IP65 rating to ensure correct operation of the electronics. Care must be taken when installing assembly to ensure the stated ambient operating conditions are not exceeded. Material Enclosure Stainless steel. Front panel membrane polycarbonate.

OPERATION AND USER CONTROLS

- The display operates in °C or °F modes. Selection of these modes is by jumper link shown over-leaf.
- If the sensor fails or is connected incorrectly, the display will read '- - -'
- There is a low battery sign in the display. This is displayed in a flashing format when the battery needs replacing. When the low battery sign is permanently on, measurement accuracy may not be within specification and therefore the battery needs replacing immediately.
- When pressed the Max / Min buttons will display the maximum and minimum temperature recorded since power up or the last reset.
- To reset the Max/ Min values, press both buttons together for 3 seconds until 'RST-' is displayed. Immediately release these buttons and the values have been reset to the current sensor temperature.

GENERAL RECOMMENDATION



The instrument is a high accuracy digital thermometer. In order to ensure correct operation the following must be observed:-

- The product must be stored in a dry clean environment and remain in original packaging prior to installation.
- The instrument must not be installed adjacent to electro mechanical starters, controllers, thyristor power units or electrical switch gear.
- Any cleaning of the instrument must be done using a mild detergent and soft cloth. No solvents or abrasive cleaners should be used.
- Any external cable entries must be sealed to at least IP65 rating.
- Stated ambient operating conditions must not be exceeded. Battery life will reduce with higher ambient operating conditions.

CALIBRATION



Warning - This instrument is a precision digital thermometer. Calibration requires high accuracy resistance sources. Failure to use the correct calibration equipment will result with errors. Due to the method used to obtain a high stability temperature reading, the instrument can only be calibrated with a pure resistance source. Electronic resistance simulators will not work correctly with this instrument.

Calibration Mode Select

A 6 pin jumper is used to select °C and °F calibration modes

To select Cal when in °C mode



To select Cal when in °F mode



Calibration Method: Calibrate at 20°C Ambient Temperature for full accuracy

1. Two precision resistance values are required for calibration. 100 R and 300 R. The tolerance for both resistance sources is $\pm 0.01\%$. Place the jumper to 'Cal' as above, turn the Sensor Select switch to '0' then connect the resistance source to the instrument input using three identical length and type wires.

2. The instrument will not allow calibration if the input source is not within close tolerance to the expected value. If in tolerance the input resistance value will be displayed. If the input resistance is above 300 R the display will indicate the top segment bar of each digit. If the input resistance is between (100 and 300) R the mid segment bar on each digit will be shown. Finally if the input is less than 100 R the lower segment bar on each digit will be on. To ensure best accuracy always calibrate both 100 R and 300 R points.

3. To Calibrate @ 100 R set links to cal mode as shown above. Set input to $100.0\text{ R} \pm 0.01\%$. Display will read "100.0" "min". Press and hold the MIN button for 6 seconds to calibrate, PASS or FAIL will be displayed at the end of this time to show the result of calibration. Release button.

4. To Calibrate @ 300 R. Set input to $300.0\text{ R} \pm 0.01\%$. Display will read "300.0" "max". Press and hold the MAX button for 6 seconds to calibrate, PASS or FAIL will be displayed at the end of this time to show the result of calibration. Release button.

5. To return unit to normal operation select either °C or °F run modes on 6 way jumper - see over-leaf.

6. However many times the unit is re-calibrated it will always retain it's factory settings. To return to factory calibration remove battery, press and hold both MAX and MIN buttons on, then replace battery with buttons still held on, this will remove the previous calibration settings and return the unit to factory values. Release buttons.