



**COUNTER - TOTALIZER
TACHOMETER - TOTALIZER
FREQUENCY METER
CHRONOMETER**

INSTRUCTION MANUAL



DM4500F

INDEX

1. OVERVIEW	5
1.1 Introduction to the DM4500F.....	5
2. GETTING STARTED?	9
2.1 Power Supply. Connectors	13
2.2 Description functions keys and LEDs in programming mode and mode RUN.....	15
2.3 Input signal (CN2) Connection	17
3. INPUT PROGRAMMING / COUNTER CONFIGURATION	18
3.1 Selection of sensor type.....	18
3.2 Diagram of programming mode: COUNTER.....	19
3.3 Counter configuration	20
3.4 Mode count programming.....	21
3.5 Programming of display	25
3.5.1 Options of the Process Variable	25
3.5.2 Brightness level configuration	27
3.5.3 Totalizer Option	27
3.5.4 Totalizer visualization	28
4. Programming Mode CHRONOMETER	29
4.1 Chronometer Configuration	30
4.1.1 Inputs	30
4.1.2 Measure	30
4.1.3 Display	31
4.1.4 Offset.....	31
4.1.5 Reset	31
4.2 Input Setup	32
4.2.1 Start Stop - Mode In-A	32
4.2.2 Start Stop - Mode In-AB	32
4.2.3 Up Down Direction uP	32
4.2.4 Up Down Direction do	33
4.2.5 Time Range.....	33
5. FREQUENCY METER / TACHOMETER	34
5.1 Frequency meter / Tachometer	37
5.1.1 Frequency meter	37
5.1.2 Tachometer RPM	37
5.1.3 Tachometer RATE	38
5.2 Display Setup	40
5.2.1 Options of the Process Variable.....	41
5.2.2 TOTAL, MAX and MIN visualization.....	43
6. LOGIC FUNCTIONS	43
6.1 Programmable functions table	45
6.1.1 Logic functions diagram	45
6.2 Programming the functions	46
7. PROGRAM PARAMETERS AND KEYBOARD FUNCTIONS LOCK-OUT	47
7.1 Security menu diagram	48
8. RESTORATION TO FACTORY CONFIGURATION	51

9. OUTPUT OPTIONS	52
9.1 SETPOINTS OUTPUT.....	53
9.1.1 Introduction	53
9.1.2 Wiring	54
9.1.3 Technical specifications	55
9.1.4 Set points menu diagram in mode Frequency meter / Tachometer.....	56
9.1.5 Direct access to set points value programming	57
9.1.6 Description of operation in mode Frequency meter, Tachometer	58
9.1.7 Set points menu Diagram in mode Counter / Chronometer	59
9.1.8 Description of mode relays operating as Counter / Chronometer	60
9.2 ANALOG OUTPUT	63
9.2.1 Introduction	63
9.2.2 Technical specifications	64
9.2.3 Analogue output menu diagram.....	64
10. TECHNICAL CHARACTERISTICS	65

1. OVERVIEW

1.1 Introduction to the DM4500F

The DM4500F from Status Instruments is a five-digit digital instrument with 2 programmable inputs that accept signals from a variety of standard sensors and pulse generators. It can be configured to work as:

- TACHOMETER + TOTALIZER (8 digits)
- TACHOMETER + DIRECTION OF ROTATION INDICATION
- FREQUENCY METER
- COUNTER 5 digits + TOTALIZER (8 digits)
- SEVERAL MODES OF COUNTER (UP, DOWN, UP/ DOWN, PHASE)
- CHRONOMETER (5 digits)

The basic instrument is a soldered assembly composed of a main board, a **tricolour programmable display** and a power circuit. Standard features of the basic instrument include the reading of the input variable as well as remote hold, reading and memory of max and min values (peak/ valley), tare and reset function, and a full complement of programmable logic functions.

The DM4500-F model can also incorporate the following output options:

COMMUNICATION

OPT4500/485 Serial RS485

CONTROL

OPT4500/mA Analogue (4 to 20) mA

OPT4500/V Analogue (0 to 10) V

OPT4500/2R (2 x Relays SPDT 8 A)

OPT4500/4R (4 Relays SPST 5 A)

OPT4500/NPN (4 NPN output)

OPT4500/PNP (4 PNP output)

All the output options are opto isolated from input signal and power supply.

PROCESS COUNTER

UP counter, **DOWN** counter and bidirectional **UP/DOWN** counter

- In **UP/ DOWN** mode it can be programmed to work:
Independent, Directional or Phase.
- Remote and front-panel reset
- Decimal point indication
- Reset may load a count value (OFFSET), programmable or entered from the display
- Multiplier/Divider factor from 0.0001 to 99999
- Programmable low frequency debounce filter (20 Hz) activates automatically when a contact closure input type is selected.
- Key-lock for RESET

TOTALIZER COUNTER

- Selectable totalizer with separate decimal point and scale factor independent from process counter.
- Count display from 99999999 to -99999999. Decimal point position programmable.
- Selectable 4 positions decimal point
- Input configuration and count mode is the same as selected for the process counter
- Alternating display of 4 digits high order part and 4 digits low order part of the value with corresponding indication H and L.
- No offset possibility
- Key-lock for the RESET function
- Remote and front-panel reset
- Scale factor from 0.0001 to 99999

CHRONOMETER

- Four ranges 999.99 s, 999 m 59 s, 999 h 59 m, 9999.9 h
- Remote and front-panel reset
- Reset may load a count value (OFFSET), programmable or entered from the display
- Counts UP or DOWN
- Key-lock for RESET

FREQUENCY METER / TACHOMETER

- Measures frequency, rpm, rate, flow and time.
- Decimal point indication
- Scale factor programmable from 0.0001 to 9999
- Display update time programmable from (0.1 to 9.9) s
- Pulse arrival time limit programmable from (1 to 99.9) s
- MAX and MIN values memorisation (TACHOMETER)

TACHOMETER WITH DIRECTION INDICATION

- The DM4500F senses direction of rotation and indicates polarity of the signal by means of LEDs represented by up and down arrows. This function requires programming the totalizer for up/down PHASE or DIREC mode.

TACHOMETER WITH TOTALIZER COUNTER

- The totalizer has the same scaling facilities as for the counter configuration thus allowing it to have two simultaneous values for the same signal, for example, speed and flow.

Programmable logic functions operated at the rear connector enhance the functionality of the meter and allow basic operations remotely.

In addition, commands through the serial port are available to allow reading and changing the setpoint values, request the display and reset to zero, etc...

Special software capabilities are programmable, lock-out for individual menus or the entire program parameters, as well as the return to factory configuration.

Programmable display colour (red, green or amber) assignable to: programming, partial count value, total, setpoints, relay activation etc.



This instrument conforms to the following community standards: 89/336/CEE and 73/23/CEE

Warning: Refer to the instruction manual to preserve safety protection.

2. GETTING STARTED

Packing contents

- Instruction manual
- Digital panel meter DM4500F.
- Accessories for panel mounting (sealing gasket and fixing clips).
- Accessories for wiring connections (plug-in terminal block connectors with a fingertip key).
- Wiring label (fixed to the product housing).
- Legend label with engineering units.
- ✓ ***Check the packing contents.***

Programming instructions

- The Instrument is programmable via the front panel keyboard and allows access to several independent programming menus for configuration of the input, the display and the logic functions. If additional options are installed (serial outputs, analogue output and relays output) once recognised by the instrument, they activate their own programming software.

Programming lock-out (See section 7).

The software can be configured to allow total programming lockout but also selective lockout of the programming parameters.

- The instrument is delivered from the factory with unlocked programming, e.g., with all the programming levels accessible to the operator

TIP! - Write down the security code and keep it in a secure place.

Dimensions and mounting

Front: 96 x 48 mm
Depth: 60 mm
Panel cut-out: 92 x 45 mm

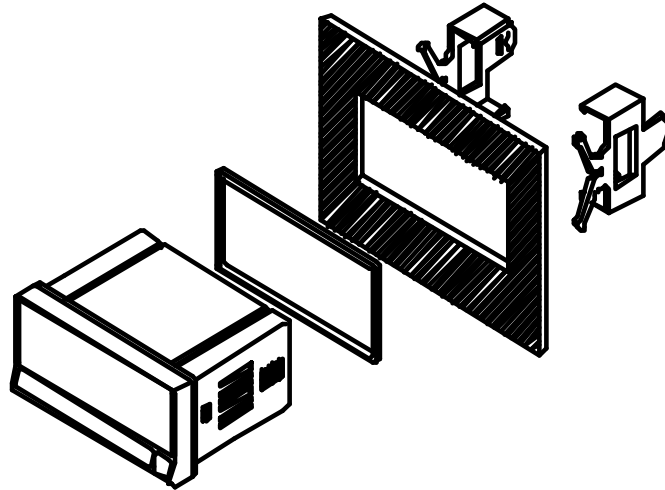

CLEANING:
Front cover should be cleaned only
with a soft cloth soaked in neutral
soap product.
DO NOT USE SOLVENTS

Programming the instrument.

First, connect the instrument to the corresponding supply; automatically a display test will be performed and the software version will be shown, then the instrument will go to run mode. Next, press the  key to enter into the programming mode, the indication "-Pro-" will appear on the display.

How to store programmed parameters?

To save the changes that have been programmed, the operator must complete the programming of all the parameters contained in the current routine. In the last step of the routine, by pressing the  key, "StorE" will be displayed and all changes are stored in memory. The instrument will then return to the run mode.

How is the programming routine organised?

Programming software is composed by a number of menus and submenus. In the diagram below, beginning with indication "-Pro-", press repeatedly on  to get access to programming menus. Blocks 3, 4 and 5 relate to output options and will only be shown if the option is fitted.

Selecting one menu, access to the different programming submenus is done by pressing  .

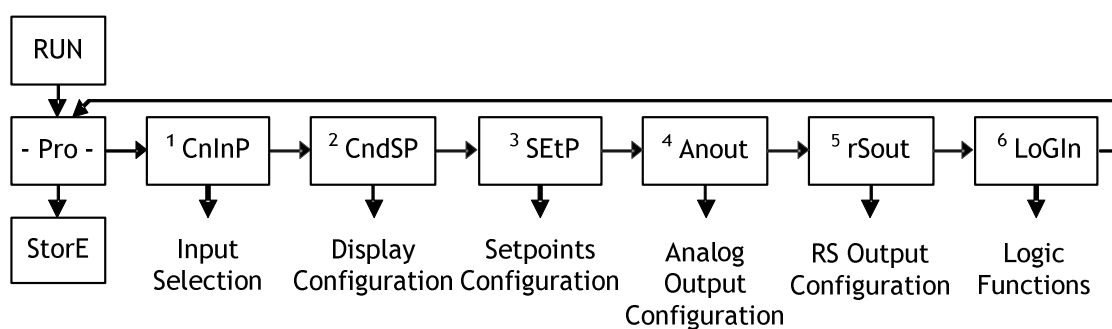



Module selection level

Accessing to programmed parameters

Because of the menu structure, the programming routines allow access to change one parameter without passing through the whole list of parameters.

To advance through programming

Progress through programming routines is done by pressing  key.

In general, push  key a certain number of times to select an option and push  key to validate the change and to go forward to the next step of the program.

The numerical values are programmed digit by digit as explained in the next paragraph.

Programming numerical values

When the parameter is a numerical value, the display will show the first digit to be programmed flashing.

Digit selecting: Press repeatedly the  key to shift from left to right over all the display digits.

Changing the digit value: Press the  key repeatedly to increase the value of flashing digit until it has the desired value.

The minus sign is programmed depending on the variable type. A variable that represents the value of an input will be able to take a value in the range -19999 to 99999, without taking into account the decimal point. When changing the first digit, this shows values from (0) to (9), and then (-1), (-), and comes back to show values from 0 to 9.

A variable that represents a display value will be able to take a value in the range -19999 to 99999, without taking into account the decimal point. In these case the first digit shows 0, 1, -1 or -.

Selecting an option from the list

When the parameter is an option to be chosen among different possibilities, the  key allows you to browse through the list of options until you find the desired parameter.

2.1 – Power Supply and connectors

WARNING: If not installed and used in accordance with these instructions, protection against hazards may be impaired.

In order to guarantee the electromagnetic compatibility, the following guidelines should be kept in mind:

- Power supply wires should be routed separately from signal wires.
- Never run power and signal wires in the same conduit.
- Use shielded cable for signal wiring and connect the shield to the ground of the indicator.
- The cable section should be $>0.25 \text{ mm}^2$

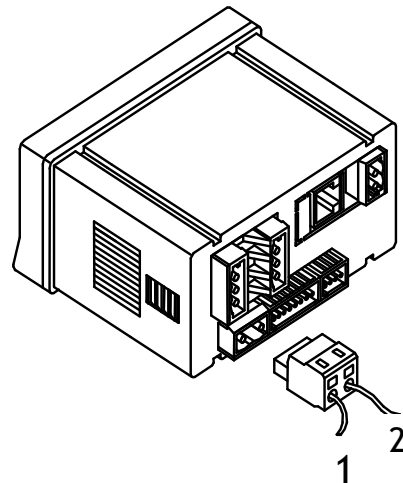

INSTALLATION

To meet the requirements of the directive EN61010-1, where the unit is permanently connected to the mains supply, it is obligatory to install a circuit breaking device within easy reach of the operator and clearly marked as the disconnect device.

WIRING and POWER SUPPLY RANGE

DM4500/S1

(85 to 265) VAC (50 to 60) Hz, or (100 to 300) VDC

DM4500/S2

(22 to 53) VAC (50 to 60) Hz, or (10.5 to 70) VDC

Pin 1: Live
Pin 2: Neutral

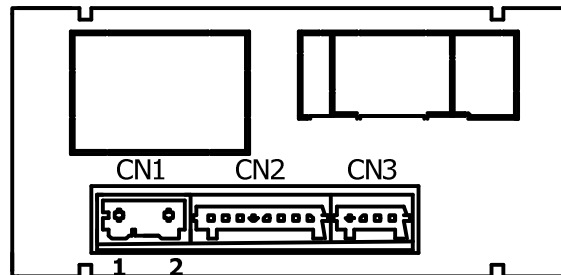

CONNECTORS

CN1 To perform wiring connections, strip the wire leaving between (7 and 10) mm exposed and insert it in the required terminal while pushing the clamp tool down to open the clamp inside the connector as indicated in the figures. CN1 terminal accepts cables of section between 0.33 mm² and 2 mm² (22 to 14 AWG)
Recommended cables size 2.0 mm²

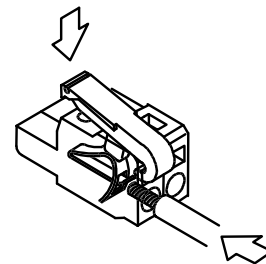

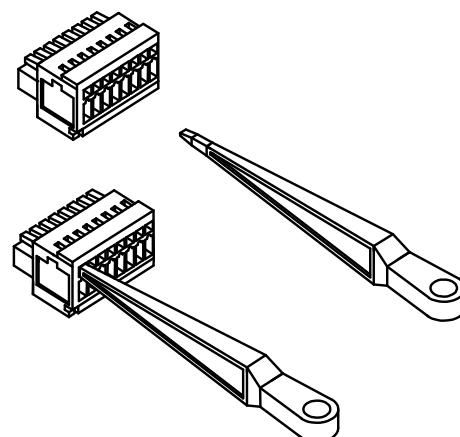

CN2 & CN3 To perform wiring connections, strip the wire leaving between (5 and 6) mm exposed and insert it in the required terminal while pushing the fingertip tool in to open the clamp inside the connector as indicated in the figures. Each terminal accepts cables of section between 0.08 mm² and 0.5 mm² (28 to 20 AWG)
Recommended cables size 0.5 mm²

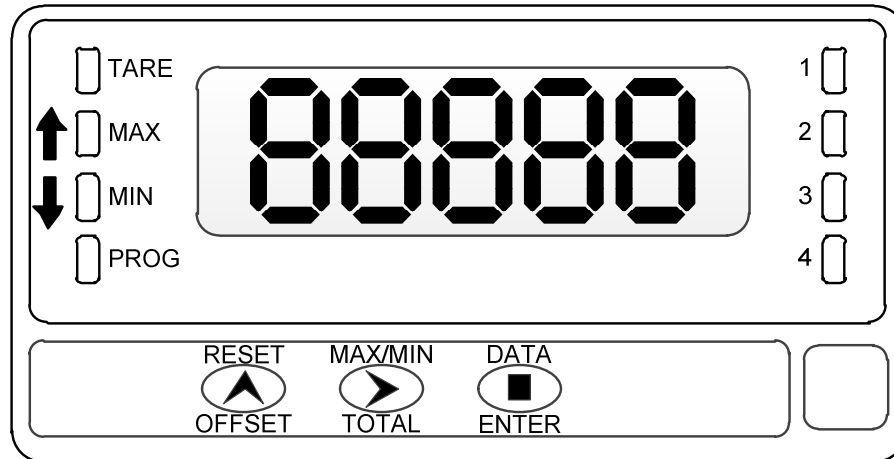

2.2 Functions keys and LED's description in programming mode and RUN mode



KEY	Function in programming mode
 DATA ENTER	<ul style="list-style-type: none"> - to step forward in programming menu - to validate programmed values - to exit programming menu
 MAX/ MIN TOTAL	<ul style="list-style-type: none"> - to move blinking digit
 RESET OFFSET	<ul style="list-style-type: none"> - to increase blinking digit value - Direct access to Setpoints value
LED's	Function in programming mode
TARE	
MAX	Indicates rotation sense (polarity)
MIN	Indicates rotation sense (polarity)
PROG	Indicates you are in programming mode
1 - 2 - 3 - 4	Indicates the Setpoint that is being programmed

KEY	Function in RUN mode
 DATA ENTER	- to enter programming menu or to visualize parameters if programming is locked
 MAX/ MIN TOTAL	1st press allows TOTALIZER visualization (if activated) 2nd press allows Max visualization (only Tachometer) 3rd press allows Min visualization (only Tachometer) Following press: back to current value.
 RESET OFFSET	In Tachometer mode reset of MAX/ MIN/ TOTAL (if present on display) In Counter mode Reset / OFFSET (starts measuring)
LED's	Function in RUN mode
TARE	Indicates that there is an offset value programmed
MAX	Fixed indicates rotation sense or count polarity Blinking indicates visualization of a Max value
MIN	Fixed indicates rotation sense or count polarity Blinking indicates visualization of a Min value
PROG	Not active in run mode
1 - 2 - 3 - 4	Indicates the activated Setpoint

2.3 – Input signal (CN2) Connection

Refer to connection recommendations on page 14

CN2

PIN 1 = No Connection

PIN 2 = (+) 18 V Excitation

PIN 3 = (+) 8.2 V Excitation
Namur sensors

PIN 4 = (-) Common
excitation / input

PIN 5 = Signal B input

PIN 6 = Signal A input

PIN 7 = No Connection

PIN 8 = High voltage input (300 Vac max.)

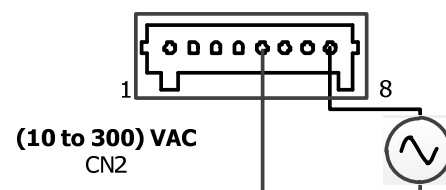
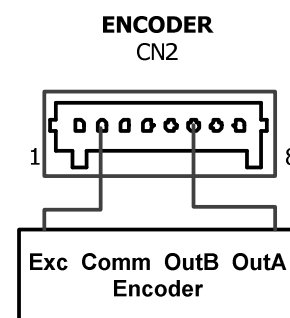
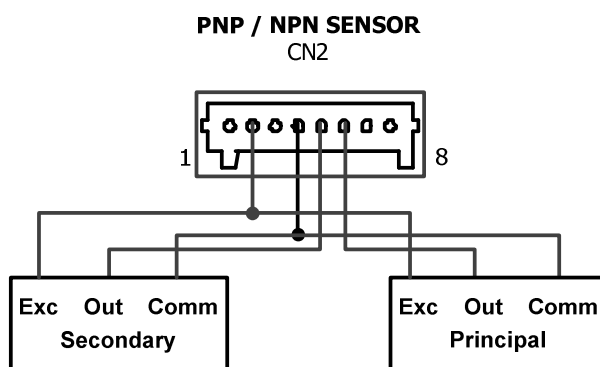
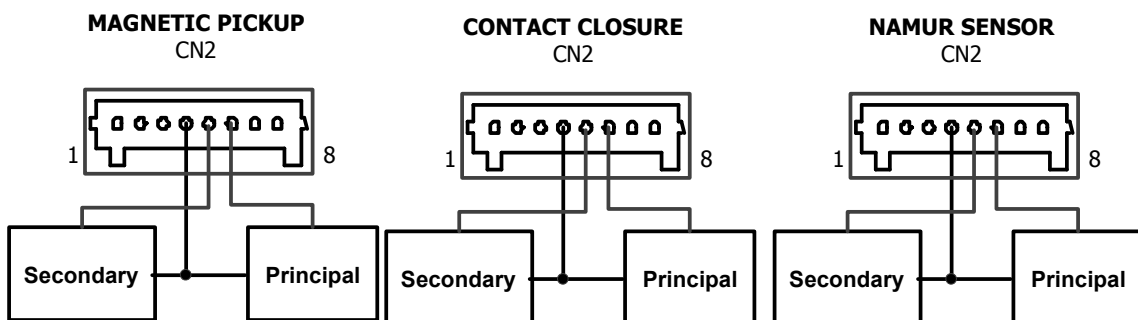
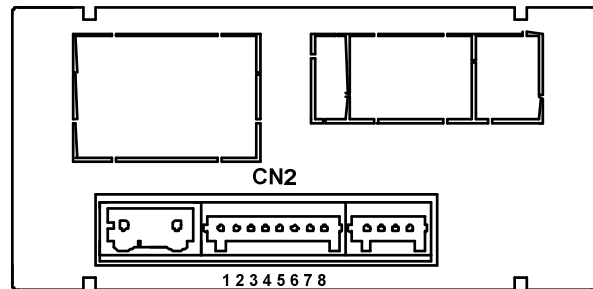

3. INPUT PROGRAMMING / COUNTER CONFIGURATION

3.1 Selection of sensor type

The diagram below shows first the configuration menu of the different sensors types, the next step is then going back into the run mode selection.

When selecting the Contact closure sensor type, anti rebound filtering will activate automatically

Both input channels are programmed automatically for the same type of sensor input.

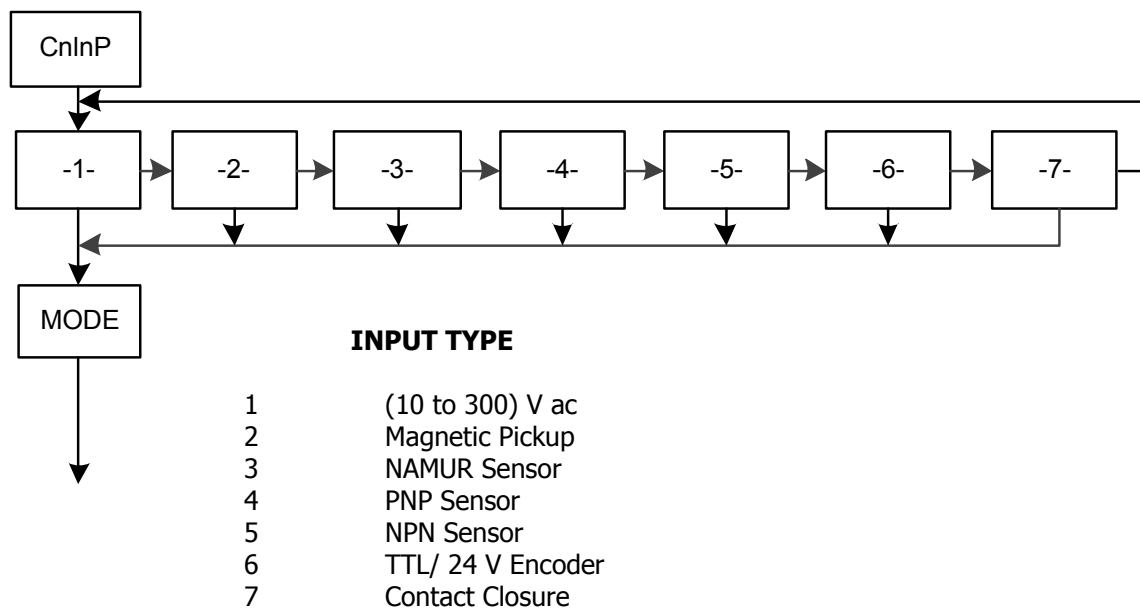

3.2 COUNTER mode programming diagram

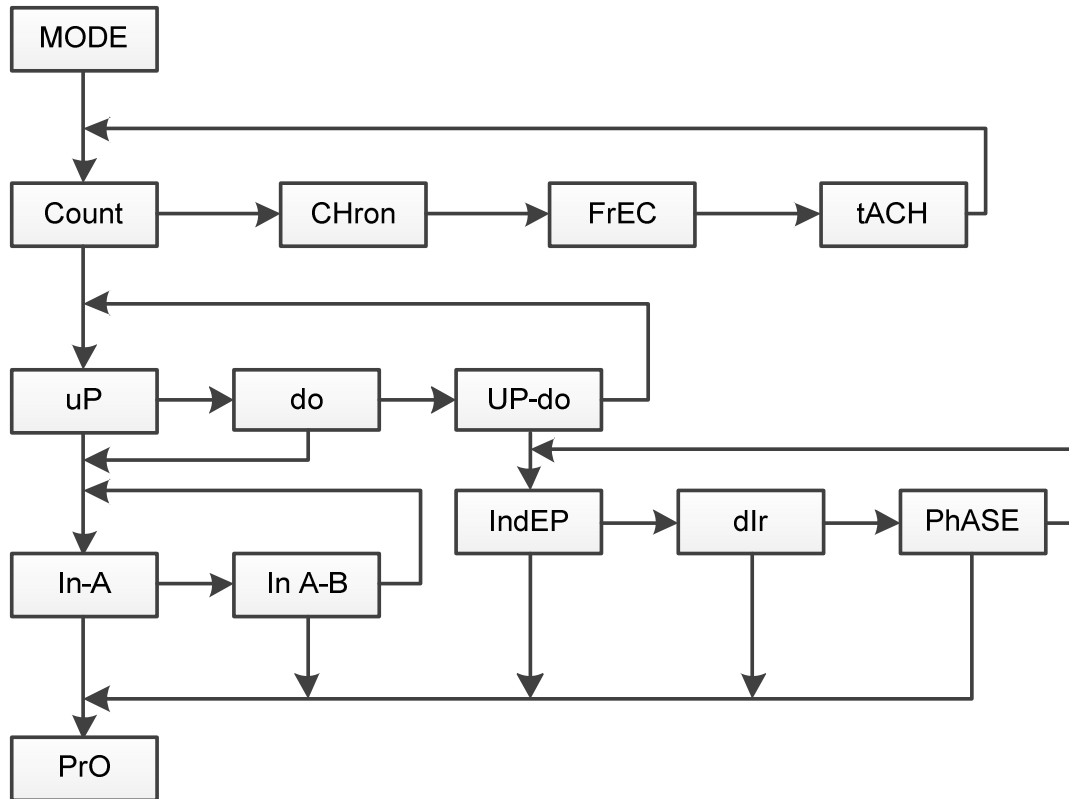

MODE

Mode selection the options are Count, CHron, FrEC and tACH

Count

SEE 3.3

Counter mode

For programming the counter mode options SEE 3.4

CHron

SEE 4.0

FrEC/tACH

SEE 5.0

3.3 Counter configuration

INPUTS

The counter has two inputs, the A input receives the pulses to count, and the B input serves to inhibit the count or to change the count direction, except in case of bidirectional counter **IndEP** where the second input is also used to count pulses.

PULSE MEASUREMENT

The pulses applied to the input are detected in the rising edge and immediately update the value of the counter and the setpoints status if the card is installed. The display updates every 100 ms. In a power failure or disconnection from the supply source, the instrument keeps the count values.

VARIABLES

The main variable of the counter is the PROCESS variable that is the number of pulses registered from the last RESET operation. If the totalizer option is enabled, we have PROC and TOTAL variables.

The TOTAL variable counts the total number of pulses received, independently of the reset operations that may take place in the process display.

DISPLAY

Process: The limits of the display are 99999 and -99999. When the instrument exceeds 99999, it shows OVER, and when it falls below -99999, it shows UNDER. The positive sign is indicated by the red LED Up arrow located on the left side of the display and the negative sign is indicated by the red LED Down arrow located on the left side of the display. The decimal point can be located in any one of the digits of the display, and it has no value, that is, the display always shows the whole part of the measurement.

Total: The limits of the display are 99999999 and -99999999. When the instrument exceeds these limits the display shows the indications OVER or UNDER.

The negative sign, when the value has less than five digits, appears in the most significant digit of the display. The negative sign is indicated by the MIN LED. When the total value has more than five digits, the display alternates the 4 digits high order part and the 4 digits low order part (the letters 'H' and 'L' in the auxiliary digit indicate which part is on display).

The decimal point can be located in anyone of the digits of the low part, and it does not have a value, the display shows the whole part of the measurement.

3.4 Mode count programming

The input setup is available on the 'CnInp' menu which allows configuration of the count mode and batch operation.

Count Modes

The software provides setup for five different count modes:

uP

Up count

do

Down count.

In-A

Allows count on A input regardless of input B

InA-B (*1)

Pulses applied at the A input are added or subtracted to the count display if the B input is at low level and being used as inhibited input.

uP-do IndEP (*2)

Pulses applied at the A input are added to the count display while pulses at the B input are subtracted.

uP-do dIrEC (*3)

When B input is at low level, the pulses applied at the A input increment the count. When B input is at high level, the pulses at the A input decrement the count.

uP-do PHASE (*4)

The rising edges at the A input increment the count if the B input is at a low level. The falling edges at the A input decrement the count if the B input is at a low level.

Unidirectional counters:

MODE uP InA-B

(*1)

A counts up if B = '0'. B = '1' inhibits count.

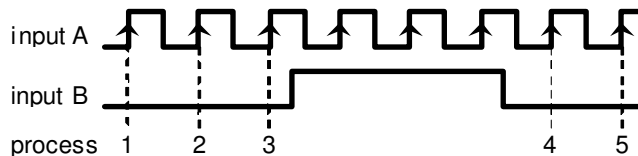

MODE do InA-B

(*1)

A counts down if B = '0'. B = '1' inhibits count.

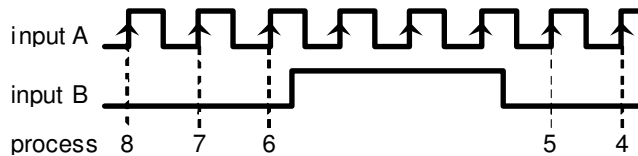

Bidirectional counters:

MODE uP-do IndEP

(*2)

A counts up. B counts down.

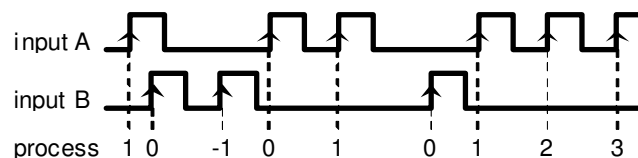

MODE uP-do dIrEC

(*3)

A counts up if B = '0' and counts down if B = '1'

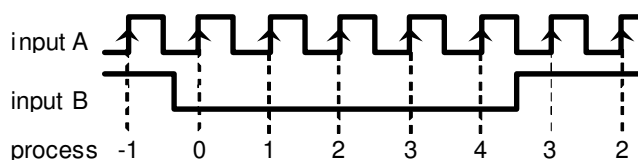

MODE uP-do PHASE

(*4)

Rising edge of A counts up if B = '0'.
 Falling edge of A counts down if B = '0'.

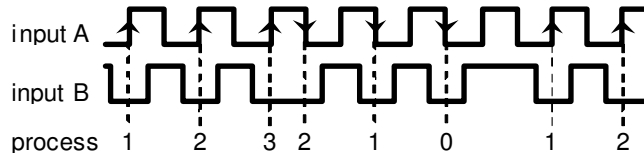

Programming diagram of the DISPLAY in MODE: COUNTER

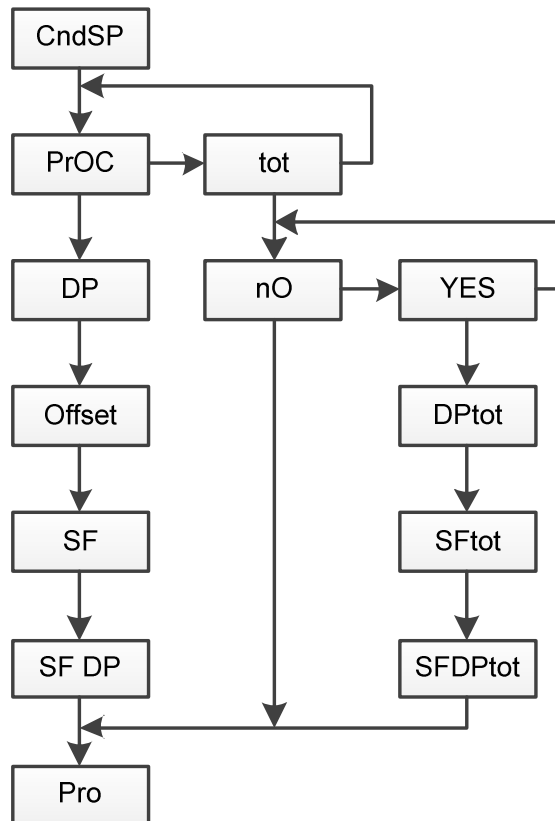

CndSP Channel display, for setting the display parameters

Proc **SEE 3.5.1**
Processes variable configuration in COUNT mode

Note: the following options do not have a heading on the DM4500F display menu and are programmed in sequence.

DP **SEE 3.5.1**
Decimal point

Offset **SEE 3.5.1**
Offset (reset value)

SF **SEE 3.5.1**
Scaling Factor

SF DP **SEE 3.5.1**
Scaling Factor decimal point (divisor)

tot **SEE 3.5.3**
Totalizer configuration in COUNT mode

no/YES **SEE 3.5.4**
Totalizer on or off

Note: the following options do not have a heading on the DM3500F display menu and are programmed in sequence

DP tot **SEE 3.5.4**
Decimal point

SF tot **SEE 3.5.4**
Scaling Factor for the totalizer

SF DP tot **SEE 3.5.4**
Scaling Factor decimal point (divisor) for the totalizer.

3.5. Scaling setup

3.5.1. Options of the Process Variable

In the menu **ProC** of the **CndSP** module can be found the parameters related to PROCESS variable measurement, -Decimal Point, Offset, and Multiplier Factor-

DECIMAL POINT

The decimal point indication helps to read the display in the desired engineering units.

The decimal point has no real value, i.e. the digits to the right of the decimal point are not actually decimals. To read values with resolution to the desired decimal places a combination of decimal point and scaling factor is required.

For example, a system that provides 100 pulses per 2 meters length of a material. To display length in meters and centimetres, you should program a factor of 2 (1 pulse = 2 cms) and place the decimal point to the left of the third digit.

OFFSET

OFFSET is the value that applies to the counter in a reset event.

By default it is zero whatever is the configuration.

Configurable in the menu **ProC**

The OFFSET is applied to the PROCESS variable exclusively.

When the OFFSET is different from zero, the LED TARE will remain active while in the run mode.

SCALE FACTOR

The scale factor is programmable from 0.0001 to 99999.

Individual decimal point location makes it possible to program any value within this range independently from the main decimal point of the display.

Any number below 1 acts like a divisor while a number above 1 acts like a multiplier. (It is not possible to program a factor=0).

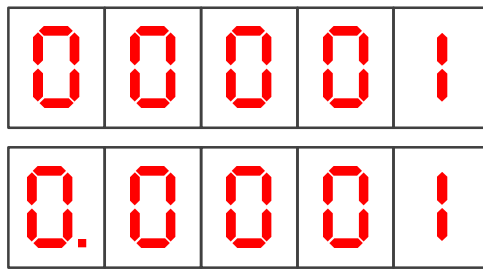

IMPORTANT: Direction sensing indication is achieved by selecting one of the bidirectional count modes PHASE or dIrEC.

"Positive sign" indication occurs when the pulses applied to the instrument increase the counter while "negative sign" indication occurs when the input pulses decrement the counter.

A change in the polarity of rate is recognized when the meter receives at least two consecutive pulses in the opposite direction of the previous pulses.

RESET KEY

Pressing the RESET key will clear to zero the variable present on the display and reinitiate the count in **counter** mode or **chronometer**, from zero or offset.

The RESET key will not operate if, in the program lock-out routine, its corresponding step is activated.

3.5.2 Configuration of display brightness level

Programming diagram of the DISPLAY in MODE: All

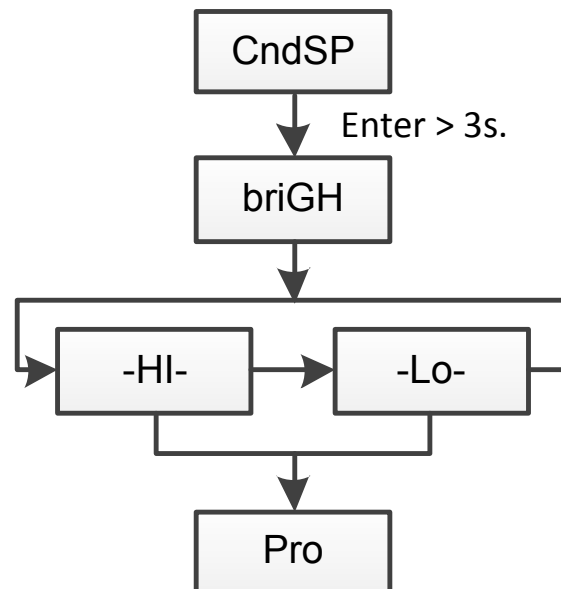

CndSP Channel display; for setting the display parameters.

briGH

Brightness setting for the display; the options are High and Low.

3.5.3. Totalizer Option

The totalizer facility can be enabled and disabled by software.

The totalizer counter shares the same input setup, count mode and count direction as the process counter but provides separate decimal point and scaling factor.

Each pulse received at the input increments or decrements the process and total counters in exactly the same way, although the displayed value may vary from one to another according to individual scaling factor and reset operations.

The limits of the display are -9999999 and 99999999 (7 digits with minus sign or 8 digits).

The decimal point can be set to five decimal places.
 The scaling factor is programmable between 0.0001 and 99999, as for the process counter.
 The totalizer has no possibility to load a user selected display value in a reset event.

3.5.4. Totalizer visualisation

The total value accumulated since the last reset will be displayed in the format indicated hereafter, when pressing on key TOTAL (if activated).

DISPLAY FORMAT

When the total value is between -9999 and 99999, it is shown on the display with the letter 'L' in the auxiliary digit and with the red led up and down arrows for positive and negative.

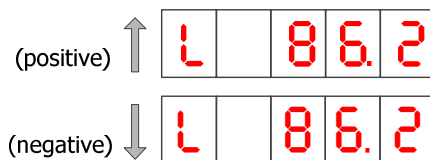

When the accumulated value exceeds 4 digits, the display alternates a 4 digit high order part (with the letter 'H' in the auxiliary digit) and a 4 digit low order part (indicated by the letter 'L' in the auxiliary digit).

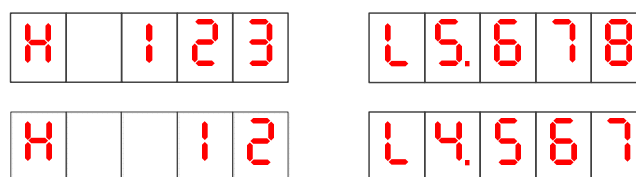

(The switching between high and low order parts takes place at a rate of approximately 2 s each part).

4.0. Programming diagram in MODE: CHRONOMETER

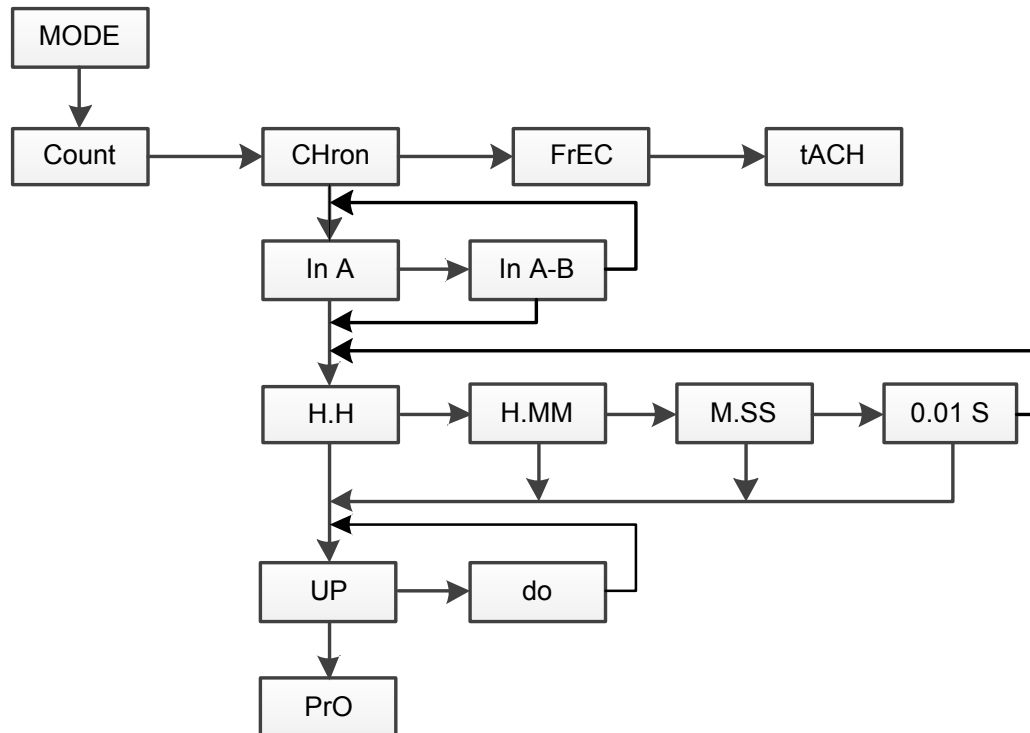

MODE

Mode selection the options are Count, CHron, FrEC, ,and tACH

CHRON

Chrono/timer mode

SEE 4.1

In A

Start mode

SEE 4.2.1

In A-B

Start mode

SEE 4.2.2

H.H/H.MM/M.SS/0.01 S

Selectable time range.

SEE 4.2.5

uP

The DM4500F counts *UP* like a stopwatch.

SEE 4.2.3

do

The DM4500F counts *Down* like a timer.

SEE 4.2.4

4.1 CHRONOMETER CONFIGURATION

4.1.1 INPUTS

The meter has two inputs for the START and STOP signals that provide different types of time measurement according to the input setup (see 4.2.1) "Start and Stop Modes").

There are two selectable operating modes:

mode In-A, this allows to measurement of the width of a pulse,

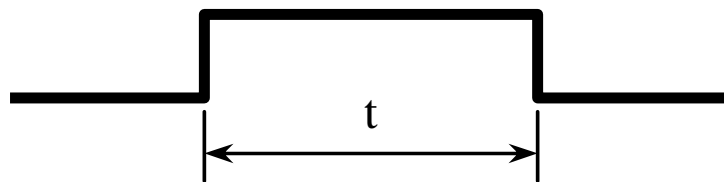

and **mode In-AB**, that is used to measure the difference between two signals

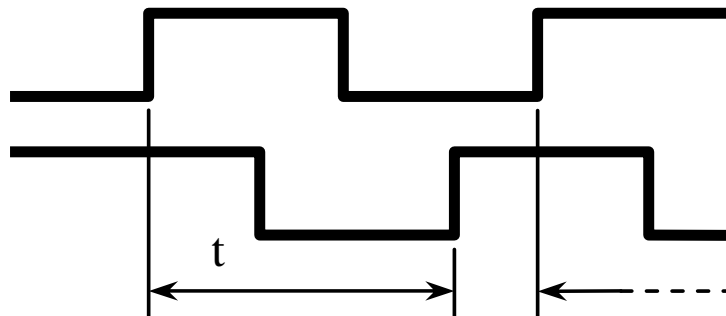

4.1.2 MEASURE

Time measurement is initiated on a rising edge of the START input. This starts up an internal counter which is controlled by a high precision crystal quartz clock.

The STOP signal suspends the internal count keeping the value of the counter for the START of the following time measurement cycle.

The counter is set to zero in a RESET operation.

In the event of a disconnection from the power source, the instrument saves the count value reached internally.

4.1.3 DISPLAY

Programming diagram of the Display in MODE: CHRONOMETER

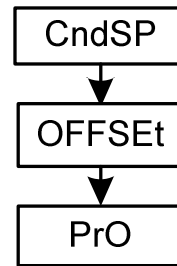

CndSP

Channel display for setting the display parameters in CHRONOMETER mode

Note: the following option does not have a heading on the DM4500F display menu and is programmed in sequence

Offset See Below

Pre set value time count down from the display can not be scaled, it only reads time in the units selected according to the programmed time range.

The decimal point appears at a fixed position according to the time range.

4.1.4 OFFSET

An offset value can be programmed for example to count down to zero from the preset time value.

The measured value, and the alarms if they exist, are updated in each minimum unit of the selected magnitude.

Display refreshment: each 100 ms.

4.1.5 RESET KEY

Pressing the RESET key will clear to zero the variable present on the display and reinitiate the count in **counter** mode or **chronometer**, from zero or offset.

The RESET key will not operate if in the program lock-out routine if its corresponding step is activated.

4.2 Input Setup

START AND STOP MODES

4.2.1

MODE In-A START on rising edge of input A.
 STOP on falling edge of input A.

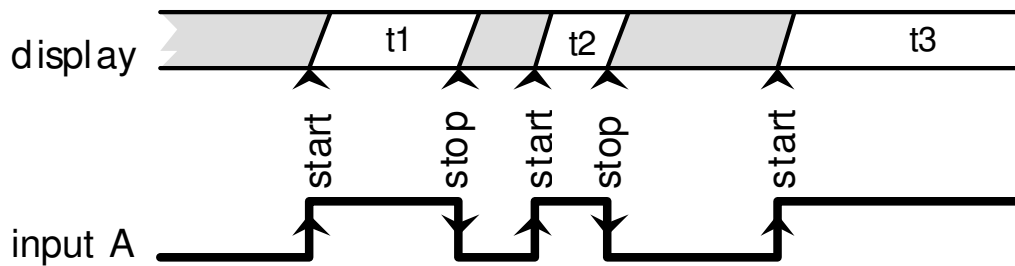

4.2.2

MODE In-AB START on rising edge if input A.
 STOP on rising edge of input B.

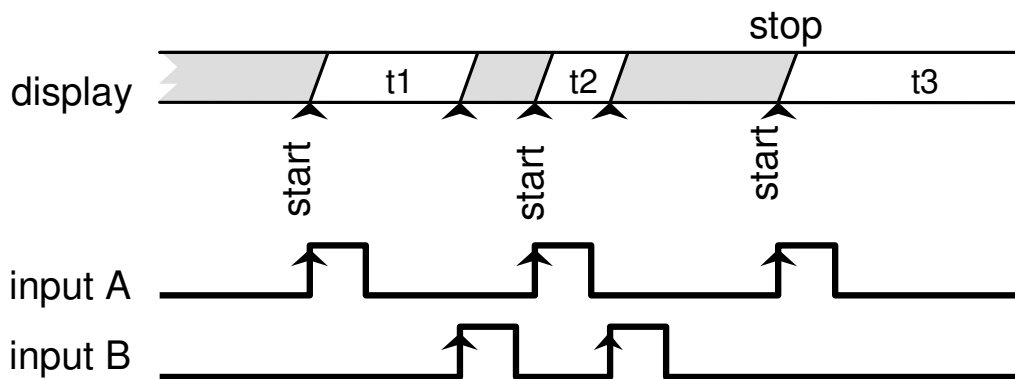

UP or DOWN DIRECTION

4.2.3 uP: The meter acts as a stopwatch. It counts up the time elapsed between the START and STOP signals.

When accumulated value exceeds from 99999, the display reads OVER.

4.2.4 do: The meter acts as a timer. It counts down from a user programmed offset to zero (a setpoint may be used to perform any function at this point).

A reset operation sets the timer to the offset value; the START signal initiates the timing count. When the accumulated value reaches 0, the next decrement makes the display read UNDER.

4.2.5 TIME RANGE

There are four selectable time ranges:

H.H	9999.9 h (resolution 0.1 hours)
H.MM	999 h 59 m (resolution 1 minute)
M.SS	999 m 59 s (resolution 1 second)
0.01-S	999.99 s (resolution 0.01 second)

The decimal point appears in the position according to the programmed time range.

(In a power failure, the meter saves the time value and the internal count value).

5. FREQUENCY METER / TACHOMETER

INPUTS

In frequency/tachometer mode both inputs to the meter are used. The signal providing frequency/rate and count information must be on the A input. A second signal may be applied to the B input to control direction of rotation or polarity of the signal.

MEASURE

The method of calculating rate is based in measuring the period of the signal, that is, the time elapsed between two consecutive rising edges. The period is converted into a high precision frequency value and scaled to read the desired units.

DISPLAY

The meter allows the user to change some parameters to fit the particular application needs, such as to reduce or extend the number of signal cycles of each reading, the time limit, the display rate and averaging (see "Options of the Process Variable" Section 5.2).

TOTALIZER

If enabled, the totalizer accumulates the number of pulses received at the input providing two simultaneous readings, for example, flow rate and product quantity, for a given process.

DIRECTION OF ROTATION INDICATION

Direction sensing indication is a matter of simply setting the totalizer to read UP/DOWN direction (modes PHASE and dIrEC).

The direction of rotation is denoted by the LED's MAX and MIN on the left of the display. LED MAX illuminates when the totalizer counts in the up direction, so it can be associated to a "positive" rate.

LED MIN illuminates when the totalizer counts down, which may be associated to a "negative" rate.

A change in the polarity of rate is recognized when the meter receives at least two consecutive pulses in the opposite direction to one of the previous pulses.

**Programming diagram for MODE: FREQUENCY METER/
TACHOMETER**

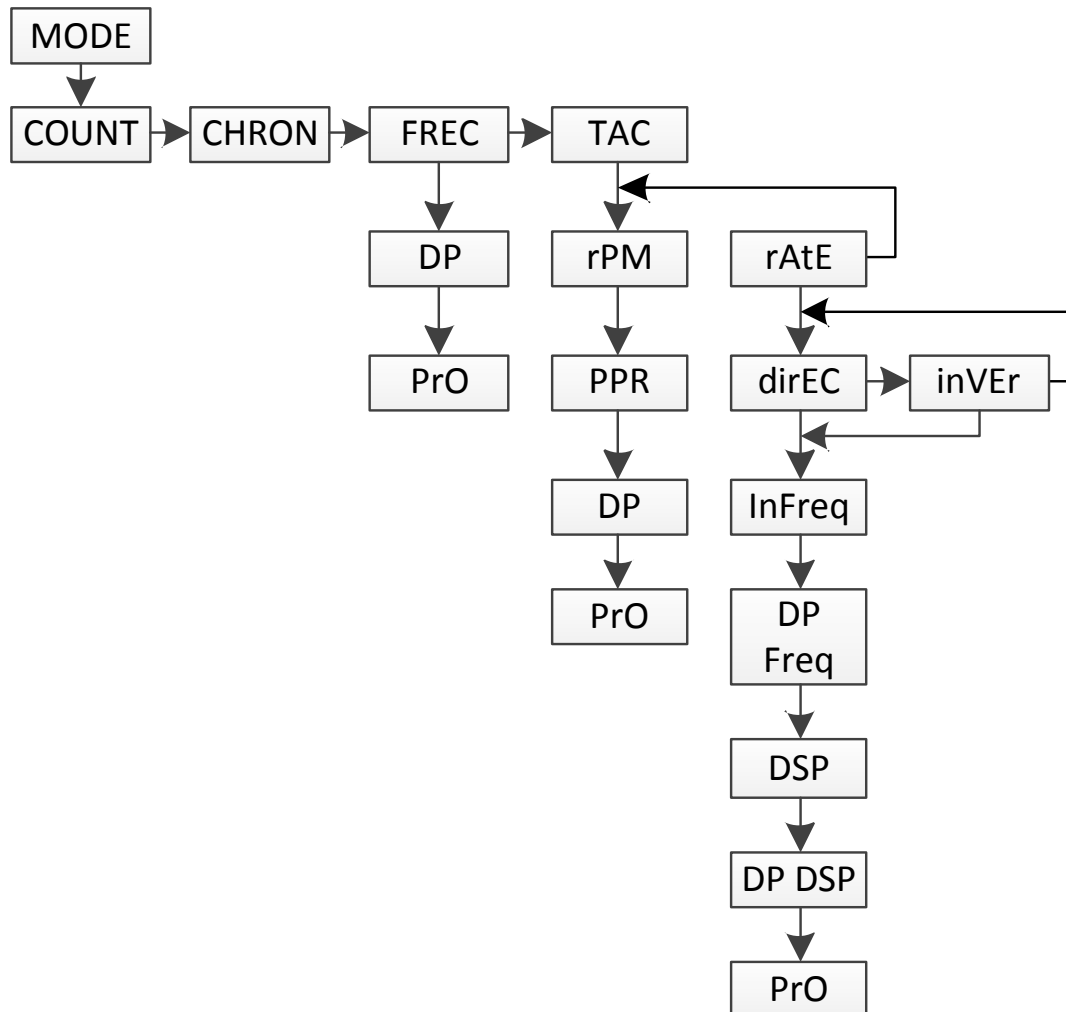

MODE

Mode selection the options are Count, CHron, FREC, and tACH

FREC

SEE 5.1

Frequency meter mode

Note: the following options do not have a heading on the DM4500F display menu and are programmed in sequence

DP **SEE 5.1.1**
Decimal Point

MODE
Mode selection the options are Count, CHron, FrEC, ,and tACH

TAC **SEE 5.1.2**
Tachometer mode

rPM **SEE 5.1.2**
Revolutions per minutes, select rpm or rate

Note: the following options do not have a heading on the DM4500F display menu and are programmed in sequence

PPR **SEE 5.1.2**
Pulses per revolution, enter a value

DP **SEE 5.1.2**
Decimal Point for the displayed value

rAtE **SEE 5.1.3**
Rate, select rate or rpm

dirEC/inVEr **SEE 5.1.3**
Direct or inverted/reversed scaling

Note: the following options do not have a heading on the DM4500F display menu and are programmed in sequence

InFreq **SEE 5.1.3**
Input Frequency, enter a value

DP Freq **SEE 5.1.3**
Decimal point for the input frequency

DSP (Value) **SEE 5.1.3**
Displayed value for given DPFreq enter a value

DP DSP **SEE 5.1.3**
Decimal point for the displayed value

5.1. Frequency meter / Tachometer

CONFIGURATION

The different configurations allow measurement of almost any process quantity based in frequency calculation.

5.1.1. Frequency meter

To use this instrument as a frequency indicator, select directly the frequency meter input.

DECIMAL POINT

The only parameter to select in this input menu is the position of the decimal point, which can be 0, 1 or 2.

The decimal point position determines the max. and min. frequencies visible on display: with two decimals, max. frequency will be 999.99 Hz and min. frequency 0.01 Hz; with one decimal, max. frequency will be 9999.9 Hz and min. frequency 0.1 Hz; and with no decimal, max. frequency is limited according to the selected options (see technical features in Section 10) and min. frequency will be 1 Hz.

5.1.2. Tachometer for RPM

In this configuration the meter reads rotational rate in revolutions per minute (RPM).

The tachometer is configured by entering the number of pulses per revolution and the decimal point location.

PPR (PULSES PER REVOLUTION)

The PPR parameter is the actual number of pulses that a sensor connected to a wheel gives to the input of the meter in a rotation of the wheel.

The method of measurement is based in calculating the time necessary for the system to produce a complete rotation of the

wheel, therefore, by default, each reading extends over the programmed number of pulses.

DECIMAL POINT

The decimal point location, in combination with a suitable scale factor, allows the display reading be expressed into other units different from RPM if desired.

5.1.3. Tachometer Rate

In this configuration the meter can be easily scaled to read direction, speed, flow or time directly in the desired units by entering only two parameters: Input Frequency and Desired Display.

DIRECT OR REVERSED INPUT SCALING

Direct scaling. The relationship between frequency and display is directly proportional, that is, the higher the frequency, the greater the display. This will be the mode to choose in most applications.

$$I/P * Y = O/P * Y$$

Reversed scaling. The relationship between frequency and display is reversed, that is, the higher the frequency, the lower the display.

DISPLAY SETTINGS

The scaling procedure consists of entering a display value corresponding to an input value. A straight line plotted from this point to zero (input=0, display=0) establishes a linear relationship between frequency and display.

In Freq INPUT FREQUENCY

For scaling purposes, the input frequency value can be programmed within all range of the display (the frequency limits are given in Section 10).

DP Freq

The input frequency can be programmed with 0, 1 or 2 decimal places. The decimal point position has value, for example, a frequency value of 200 Hz can be programmed as 200, 200.0 or 200.00

DSP**DESIRED DISPLAY**

**IN THIS PHASE ENTER THE DISPLAY VALUE
CORRESPONDING TO THE PROGRAMMED INPUT
FREQUENCY.**

DP DSP

The decimal point can be located in any of the digits of the display to help reading the display in the desired units.

5.2. Display Setup

Programming diagram of the DISPLAY in mode: FREQUENCY METER / TACHOMETER

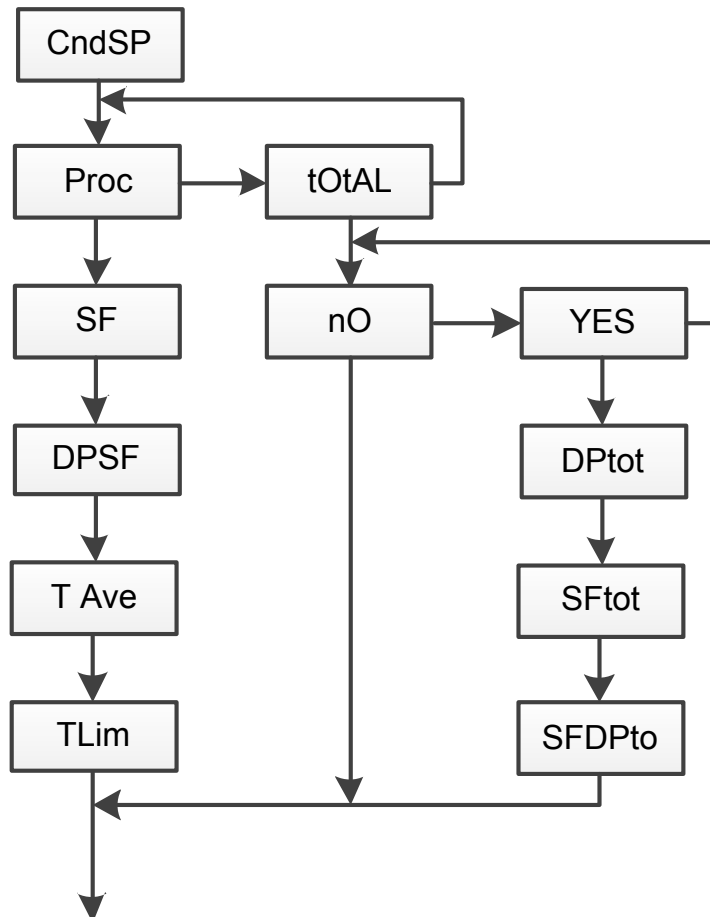

CndSP

Channel display; for setting the display parameters in FREQUENCY METER/ TACHOMETER mode

Proc

SEE 5.2.1

Channel display; for setting the display parameters

SF

SEE 5.2.1

Scaling Factor for the displayed value

SFDP

SEE 5.2.1

Scaling Factor decimal point (divisor)

T Ave

SEE 5.2.1

The time limit is initialized at the reception of each input pulse. If no more pulses are detected before the time limit runs out, the display is forced to zero.

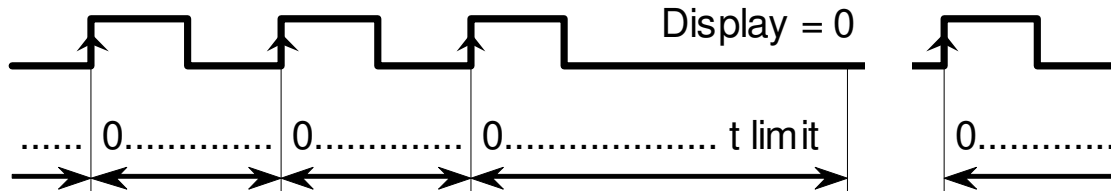

Decreasing the limit time makes the instrument respond more quickly to the zero condition when the system stops.

Nevertheless, this reduction will also cut the lowest frequencies (for example: with a time limit of 10 s, it would be impossible to see frequencies under 0.1 Hz and with a time of 1 s, frequencies under 1 Hz).

AVERAGE TIME

The average time is a time interval in seconds during which all readings calculated from the input are averaged.

The average time is programmable from (0 to 9.9) seconds. To disable this feature program 0.

When the display presents unwanted variations, due to an irregular input signal, programming the average time for a larger value may help stabilize the display.

The average time can be calculated for a desired number of readings knowing the signal frequency.

Example: With a setup of 0.1 s, if the input signal frequency is of approx. 10 Hz or less, the meter will only take one reading every 0.1 s making no average. With an input signal of approx. 100 Hz, the meter will be able to collect and average about 10 readings in 0.1 s. If the input signal is of approx. 1000 Hz, the display will read out the average of about 100 readings.

RESET KEY

The RESET key in **Tachometer** mode allows setting of the Max and Min memories to the current value.

To re set the MAX or MIN value to the current value, set the display to Max or Min as required and press the reset key.

To reset the **totalizer** it is necessary to recall the TOTAL variable on to the display by pressing the TOTAL key and then pressing RESET.

The RESET key will not operate if, in the program lock-out routine, its corresponding step is activated.

5.2.2 TOTAL, MAX and MIN Display

In **tachometer mode** one push on the MAX/MIN key shows, when activated, the total value in the programmed colour; next push shows the peak value with the flashing led MAX indicator; next push shows the valley value with the flashing led MIN indicator; another push brings us back to current value indication.

6 – LOGIC FUNCTIONS

The rear connector CN3 provides 3 user programmable opto-coupled inputs that can be operated from external contacts or logic levels supplied by an electronic system. Three different functions may be added to the functions available from the front-panel keys. Each function is associated to one pin (PIN 2, PIN 3, PIN 4) and is activated by applying a falling edge or a low level pulse to the corresponding pin with respect to common (PIN 1).

Each pin can be assigned one of the 8 functions listed on the following pages.

- Factory configuration

Functions associated to Connector CN3 in factory configuration are: OFFSET, RESET and RESET TOTALIZER.

CN3: FACTORY CONFIGURATION

PIN (INPUT)	Function	Number
PIN 1	COMMON	
PIN 2 (INP-1)	OFFSET	Function No 1
PIN 3 (INP-2)	RESET	Function No 2
PIN 4 (INP-3)	RESET TOTALIZER	Function No 6

Logic functions diagram

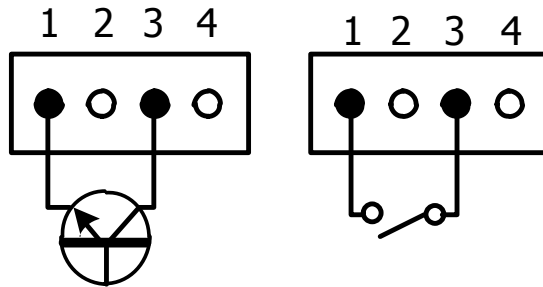

The external electronics applied to the CN3 connector must be capable of withstanding 40 V and 20 mA present at all terminals with respect to COMMON.

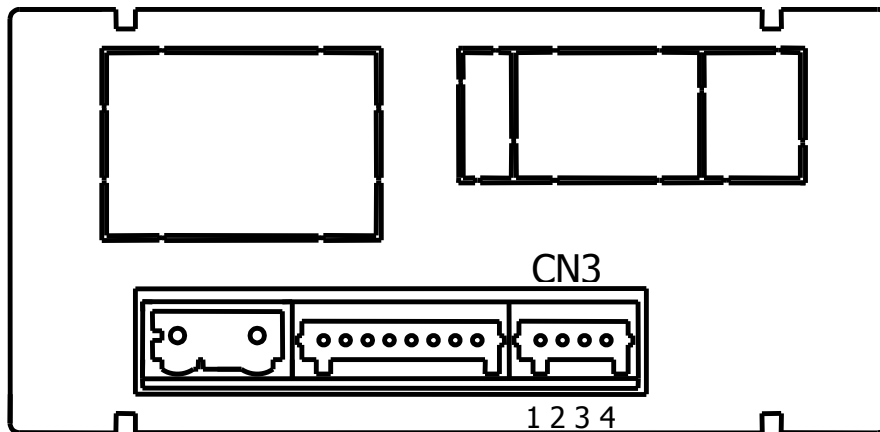

6.1 – Programmable functions table

- No: Number to select the function via software.
- Function: function name.
- Description: Function operation and characteristics.
- Activation by :

Falling edge: the function is activated applying a falling edge to the corresponding pin with respect to common.

Low level: The function will remain activated as long as the corresponding pin is held at a low level.

6.1.1 – Logic functions diagram

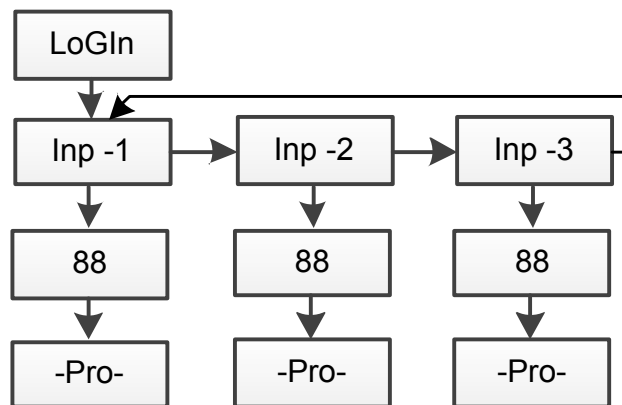

Nº	Function	Description	Activation by
0	Deactivated	None	None
1	OFFSET	Adds the current display value to the offset memory and sets the display to zero.	Falling edge
2	RESET	Sets to zero the partial counter value (Proc)	Falling edge
3	MAX	Displays the peak value. (MAX.) In Tachometer mode.	Low level
4	MIN	Displays the valley value. (MIN) In Tachometer mode.	Low level

5	RESET MAX/ MIN	Clears the peak or valley readings (the one shown in the display).	Falling edge
6	RESET TOTALIZER	Sets the TOTALIZER to zero.	Low level
11	BRIGHTNESS	Change the display brightness from Hi to Low	Low level
12	SETPOINT VALUE	Displays the selected setpoint value (see diagram next page)	Low level
13	False Setpoints	Simulates that the instrument has a four setpoints option installed	Low level

6.2 – Program of functions

0 to 13

If the selected function is number 13 and any of the 2R, 4R, 4NPN, 4PNP options are installed, the user will have to choose one of the two or four setpoints available depending on the option, which will be the value displayed by the instrument when this function is activated.

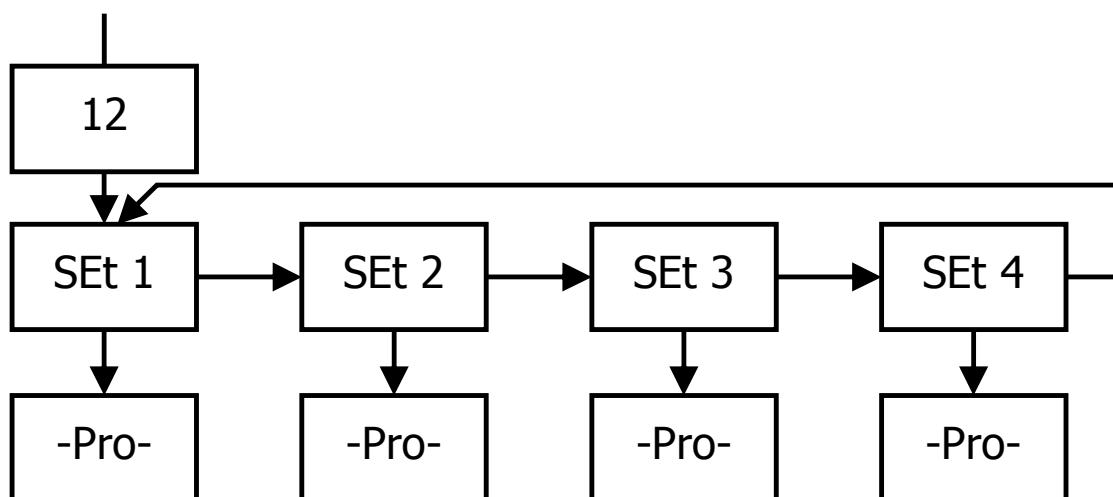

7. PROGRAM PARAMETERS AND KEYBOARD FUNCTIONS LOCK-OUT

The instrument is supplied with all software programming parameters accessible to the operator's modifications. After completing the software configuration, it is recommended to protect configuration settings by the following steps:

1. Lockout programming parameters to protect from accidental or unauthorized modifications.
2. Lockout keyboard functions to prevent accidental or unauthorized modifications.
3. There are two modes to lock-out the program parameters; total or selective. If some parts of the program have to be adjusted at a later time, make a selective lock. If you don't need to make changes, make a total lock.
4. Access to the lockout routine is allowed by entering a safety code. At factory this code is set to **0000**. We recommend changing this code, and writing it down and keeping it in a safe place.

TOTAL LOCKOUT

The access to the programming routines to read data is allowed even if all parameters are locked out totLC=1, but **it will not be possible to enter or modify data**. In this case, when entering in the programming mode, the display shows the indication "-dAtA-".

SELECTIVE LOCKOUT

When only some parameters are locked out, all configuration data can be read but **only non-protected parameters can be modified**. In such case, when entering in the programming mode, the display shows the indication -Pro-.

Menus or submenus that can be locked out are:

- Setpoint 1 configuration (SEt 1).
- Setpoint 2 configuration (SEt 2).
- Setpoint 3 configuration (SEt 3).
- Setpoint 4 configuration (SEt 4).
- Input configuration (InPut).
- Display (dsp)
- Analog output configuration (Anout).
- Serial output configuration (rSout).
- Logic inputs configuration (LoGIn).
- Lock-out of the reset key, not of the logic function.
- Offset value configuration
- Direct access to the Setpoints value configuration (SEtVAL).

The first four and "SEtVAL" only appear if the corresponding option OPT4500/2R, OPT4500/4R, OPT4500/NPN or OPT4500/PNP have been installed, "Anout" will appear when any of the OPT4500/mA or OPT4500/V options are installed, and "rSout" when any of the OPT4500/2R or OPT4500/4R options are installed.

7.1 – Security menu diagram

The following flow chart shows the security menu for the programming lockout. Access to this menu is from the run mode by pressing the  key for 3 seconds, until the "CodE" indication appears.

The instrument is shipped from the factory with the following default code: "0000". When this code is entered, the "LISt" indication will appear, from which the parameters lockout can be entered. Access to the "CHAnG" menu will allow the user to change the default code to one of their own choice. Changing the personal code overwrites the original code.

If an incorrect code is entered, the instrument will return automatically to the run mode.

Total lockout programming is achieved by changing "totLC" to 1, changing it to 0, will lead to the selective lockout of the programming variables. Programming each one of the parameters

to 1 will enable the lockout; if they are set to 0 programming will be accessible. Though the programming is locked out, it remains possible to view the current programming. The "StorE" indication informs that the modifications have been stored correctly.

Code

Enter 4 digit pass code (default 0000) and press ENTER key the options are;



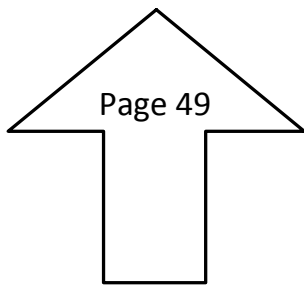

0 allows programming
1 locks access to programming

*** Only appear if the corresponding options have been installed**

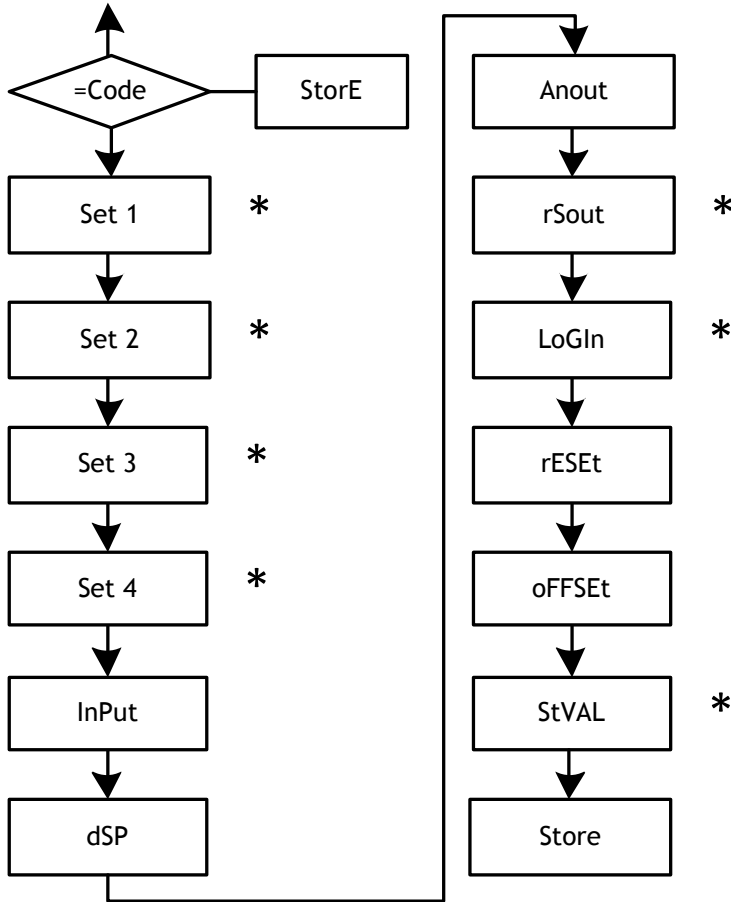

LISt
totLC
 1 = total lockout
 0 = selectable lockout

CHANG

 Select new 4 digit
 passcode

CoLor
run
 Select display colour for run
 mode
Pro
 Select display colour
 for programme mode

8. RESTORATION OF FACTORY CONFIGURATION

Following the diagram below, factory configuration can be restored:

CnInP	= - 6- , Encoder /TTL, Count, uP-do, PHASE.
CndSP	= ProC without decimal; offset=0, multiplying factor= 1, without decimal; Tot YES, without decimal, multiplying factor= 1, without decimal.
Setpoint 1	= on, ProC=1000, mode=1, latch, alarm= red, Tot=1000, mode=1, latch, alarm= red.
Setpoint 2, 3, 4	= same as Sepoint 1 but setpoint value to 2000, 3000 and 4000.
Anout	= outHI= 1000, outLo=0000.
rSout	= Baud 9600, Adr= 01, trans= Prt 2.
LoGIn	= InP-1=1, InP-2=2, InP-3=6.

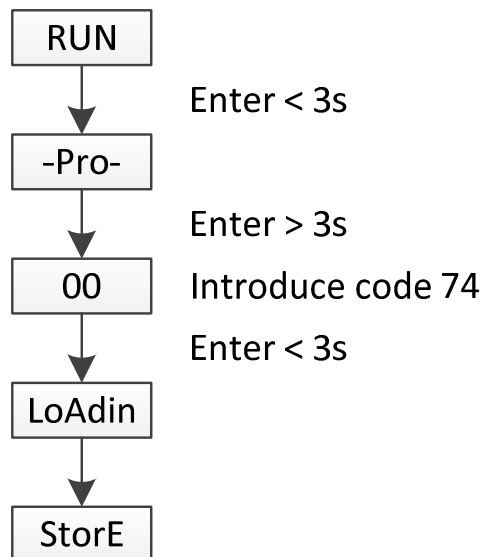

9. OUTPUT OPTIONS

The following output options are available for control or communication:

Communication options

OPT4500/485	Serial RS485
Refer to the Communications Manual	

Control options

OPT4500/mA	Analog (4 to 20) mA
OPT4500/V	Analog (0 to 10) V
OPT4500/2RLY	2 Relays SPDT 8 A
OPT4500/4RLY	4 Relays SPST 5 A
OPT4500/NPN	4 NPN outputs
OPT4500/PNP	4 PNP outputs

All mentioned options are isolated with respect to input signal and power supply, each one activates its own programming modules that provides complete software configuration.

Additional capabilities of the unit with output options:

- Control and processing of limit values via ON/OFF logic outputs (2 relays, 4 relays, 4 NPN outputs or 4 PNP outputs) or proportional output (4 to 20) mA, (0 to 10) V.
- Communication, data transmission and remote programming via serial interface.

The OPT4500/RLY, NPN, PNP options are alternatives and only one of them can be used.

The OPT4500/mA and OPT4500/V options are alternatives and only one can be used.

Up to three output options can be present at the same time and operate simultaneously:

- One analogue mA or V
- One RS485
- One 2RLY or 4RLY or 4 NPN or 4 PNP

9.1 –SETPOINTS OUTPUT

9.1.1 – Introduction

An option of 2 or 4 SETPOINTS, programmable within the full display range, can be incorporated to the unit thus providing alarm and control capabilities by means of individual LED indicators and relay or transistor outputs. Programming of the set points can configure; setpoint value, time delay (in seconds), asymmetrical or symmetrical hysteresis (in counts of display value) and selectable HI/LO trip action.

The setpoint option consists of an optional card that activates its own programming module, they are totally configurable by the user and their access can be locked out via software.

These are the control output options available:

OPT4500/2RLY: 2 Relays SPDT 8 A

OPT4500/4RLY: 4 Relays SPST 5 A

OPT4500/NPN : 4 NPN outputs

OPT4500/PNP : 4 PNP outputs

9.1.2 – Wiring

OPT4500/2RLY 2 RELAY OPTION

PIN 4 = NO2 PIN 1 = NO1
 PIN 5 = COMM2 PIN 2 = COMM1
 PIN 6 = NC2 PIN 3 = NC1

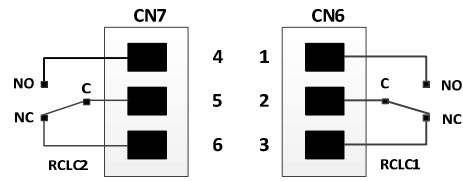

OPT4500/4RLY 4 RELAY OPTION

PIN 4 = RL4 PIN 1 = RL1
 PIN 5 = N/C PIN 2 = RL2
 PIN 6 = COMM PIN 3 = RL3

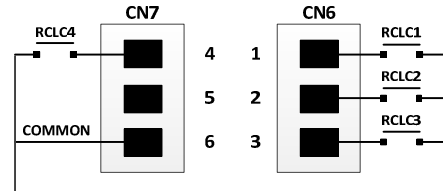

OPT4500/NPN NPN OPTION

PIN 4 = OP4 PIN 1 = OP1
 PIN 5 = N/C PIN 2 = OP2
 PIN 6 = COMM PIN 3 = OP3

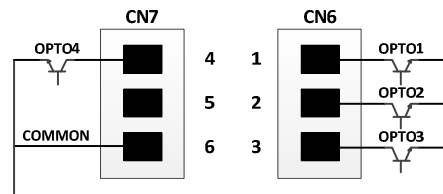

OPT4500PNP PNP OPTION

PIN 4 = OP4 PIN 1 = OP1
 PIN 5 = N/C PIN 2 = OP2
 PIN 6 = COMM PIN 3 = OP3

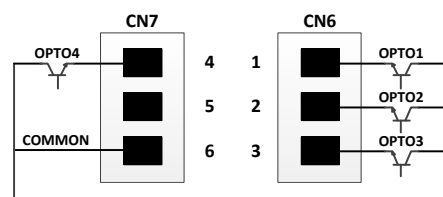

NOTE: In case that the outputs are used to drive inductive loads, it is recommended to add an RC network between the coil terminals (preferably) or between the relay contacts to limit electromagnetic effects.

Optional Output Connections

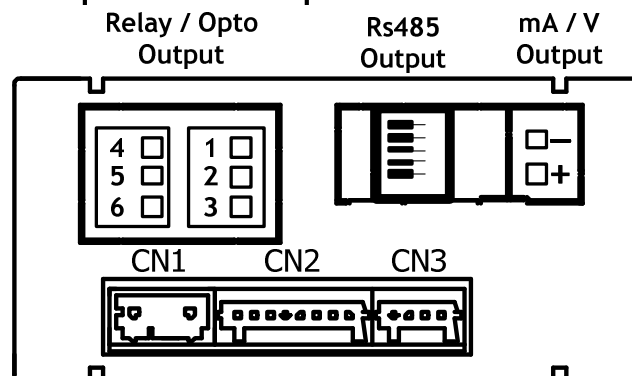

9.1.3 – technical specifications

CHARACTERISTICS	OPT4500 / 2RLY	OPT4500 / 4RLY
MAX.CURRENT (RESISTIVE LOAD)	8 A	5 A
MAX.POWER	2000 VA / 192 W	1250 VA / 150 W
MAX.VOLTAGE	250 VAC / 150 VDC	277 VAC / 125 VDC
CONTACT RESISTANCE	Max. 3 mΩ	Max. 30 mΩ
SWITCHING TIME	Max. 10 ms	Max. 10 ms

OPT4500/NPN and PNP	
MAX VOLTAGE	50 VDC
MAX CURRENT	50 mA
LEAKAGE CURRENT	100 μA (max.)
SWITCHING TIME	1 ms (max.)

9.1.4 Setpoints menu diagram in mode frequency meter / Tachometer

The complete programming of one of the setpoints is showed here, it is valid for the rest of the setpoints.

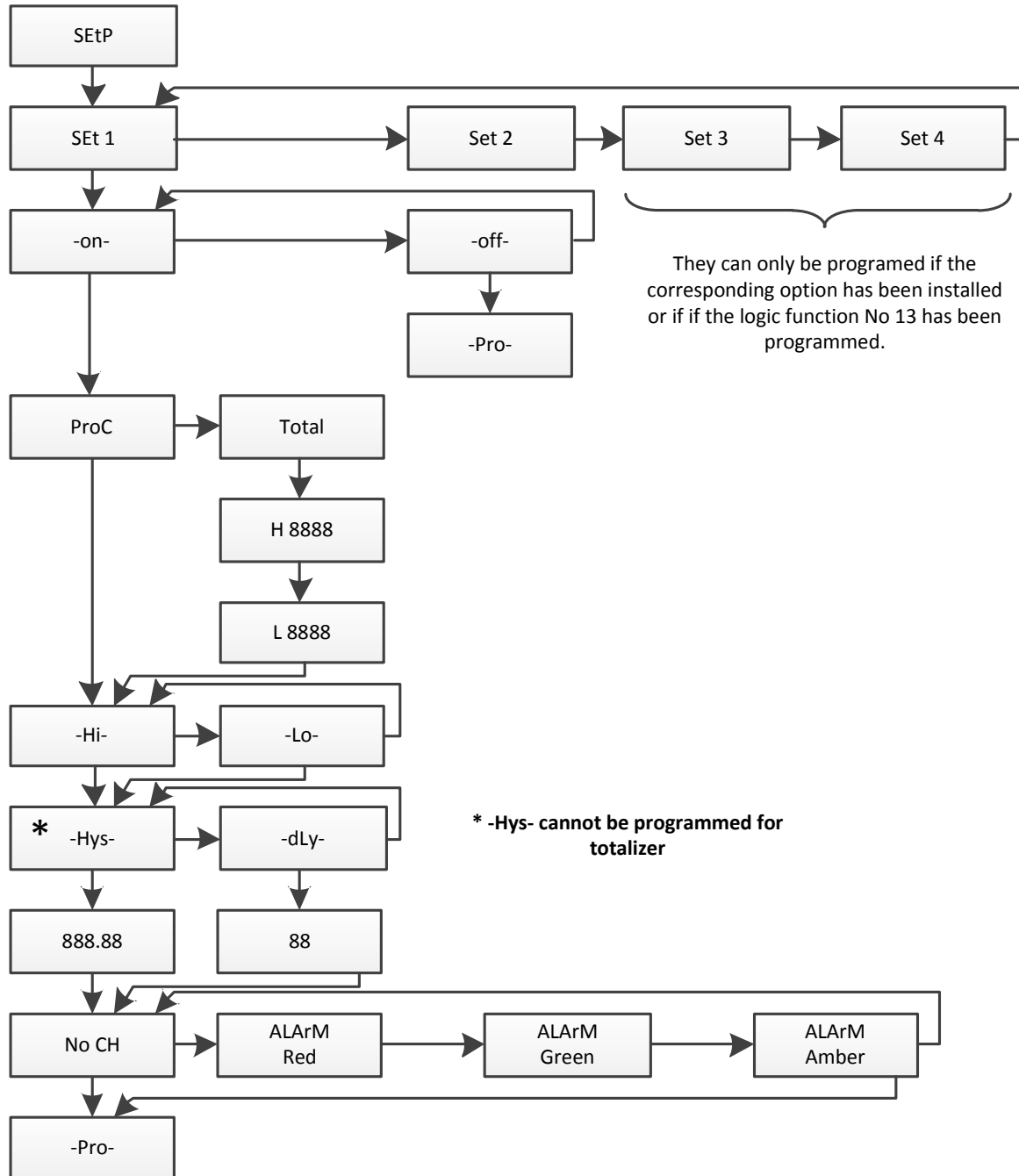

9.1.5 – Direct access to the setpoints value programming

If any of the options corresponding to the setpoints have been installed, it is possible to directly access the setpoints value without the need to go through the programming menu just by pressing the  key in PROG mode, as showed in diagram below.

NOTE: The decimal point position will be determined by what has been programmed in the SCAL menu.

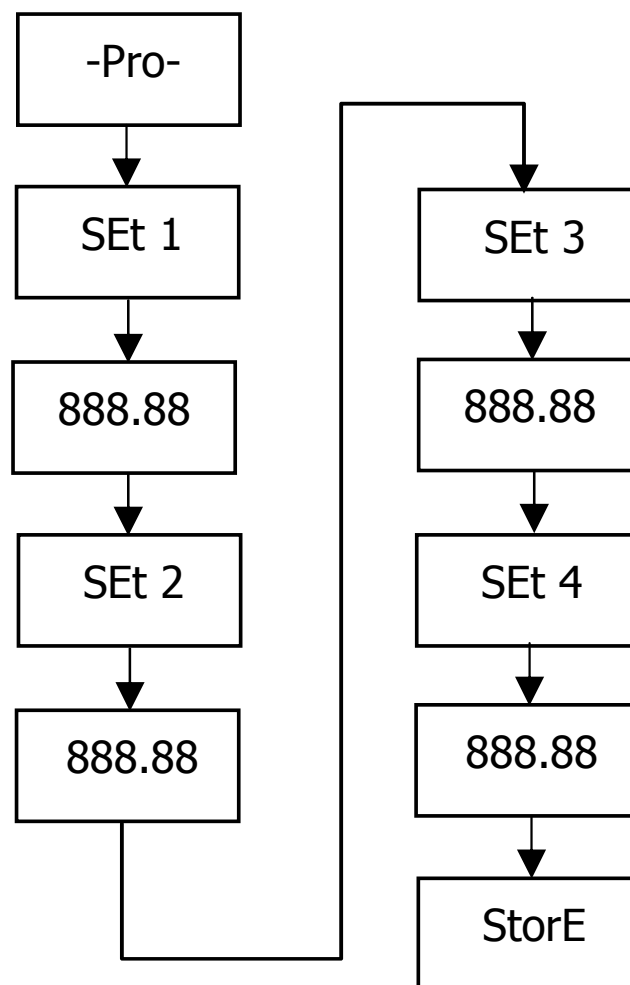

9.1.6 – Description of operation in Frequency meter, Tachometer mode.

Programmed like independent setpoints, the alarm outputs activate when the display value reaches the user-programmed value. The independent alarm programming requires definition of the following basic parameters:

b. HI/ LO ACTING MODE.

In HI mode, the output activates when the display value exceeds the setpoint level and in LO mode, the output activates when the display value falls below the setpoint

c. PROGRAMMABLE TIME DELAY or HYSTERESIS.

Each output action can be deferred by a programmable time delay or hysteresis level.

The time delay is the time that it takes the output to activate after passing through the setpoint in the up or down direction, while the hysteresis band will be selected asymmetrical i.e. only acts on the output deactivation edge.

The delay is programmable in seconds, from 0 to 99.

The hysteresis can be programmed, in counts, within the full display range. The decimal point appears in the same position as programmed in the display configuration module.

The figures below show the time delay action (dly) and the asymmetrical hysteresis action (hys) of two alarms (SET1 and SET2) programmed to activate in HI mode (OUT1) and LO mode (OUT2)

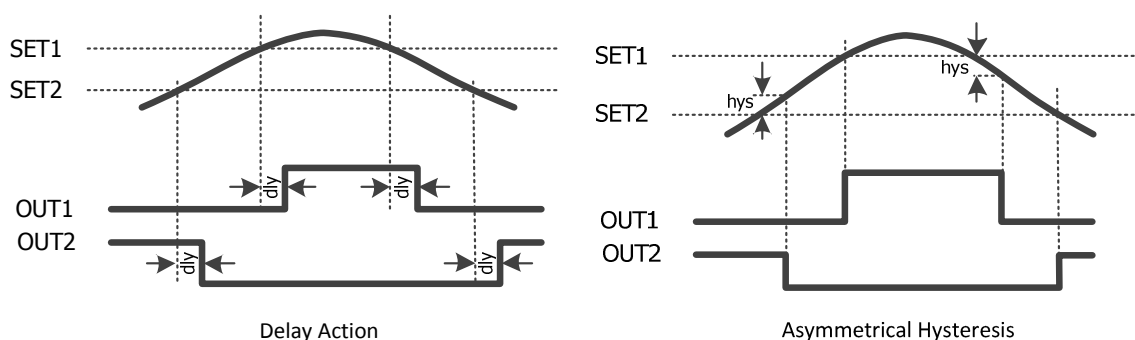

9.1.7 – Diagram of the menu of Setpoints in mode Counter / Chronometer

The complete programming of one of the setpoints is showed here, it is valid for the rest of the setpoints.

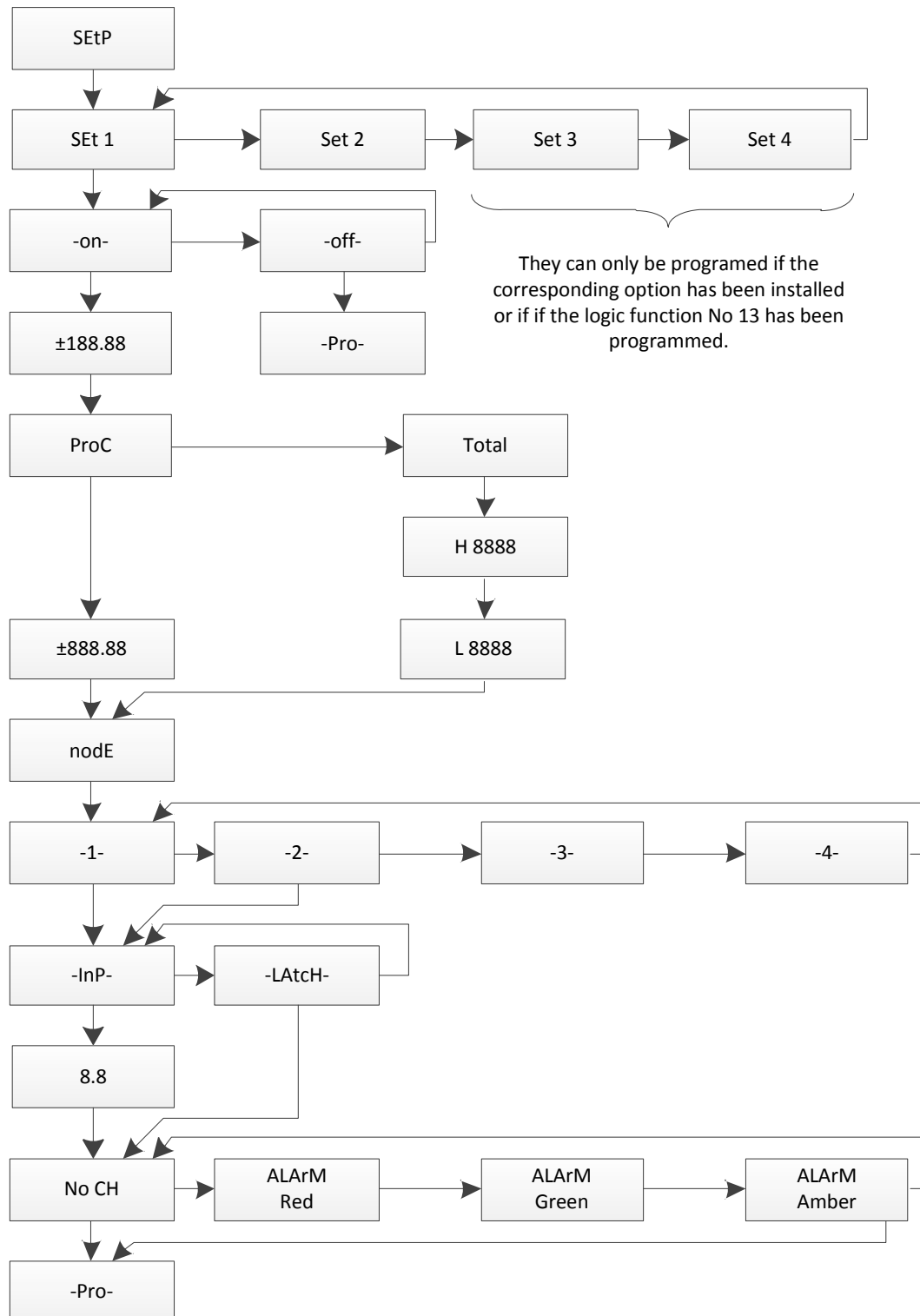

9.1.8 - Description of Mode relays operating as Counter/Chronometer

Mode 1 No function. When configured as Process or total counter, enables the output (pulse or latch), whether it comes from a lower or higher value than the programmed value.

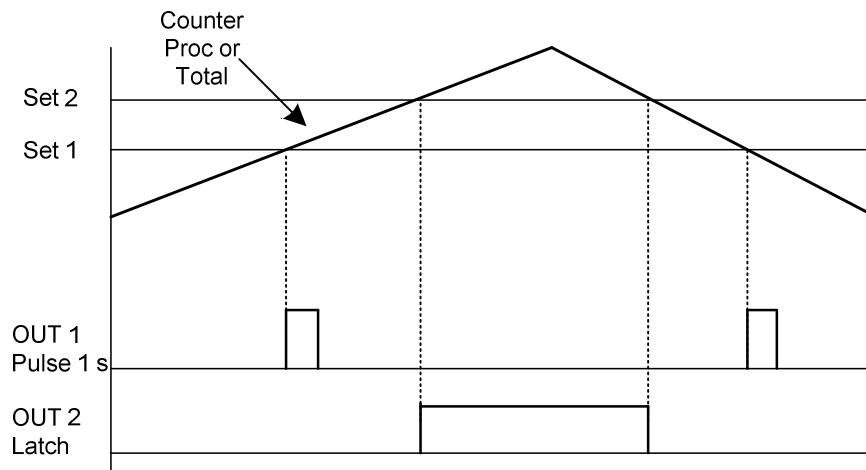

Mode 2 Reset

The value of the variable to which the setpoint is related is reset to zero (or to the offset value) when enabling output. In this mode the output **cannot be programmed as Latch**.

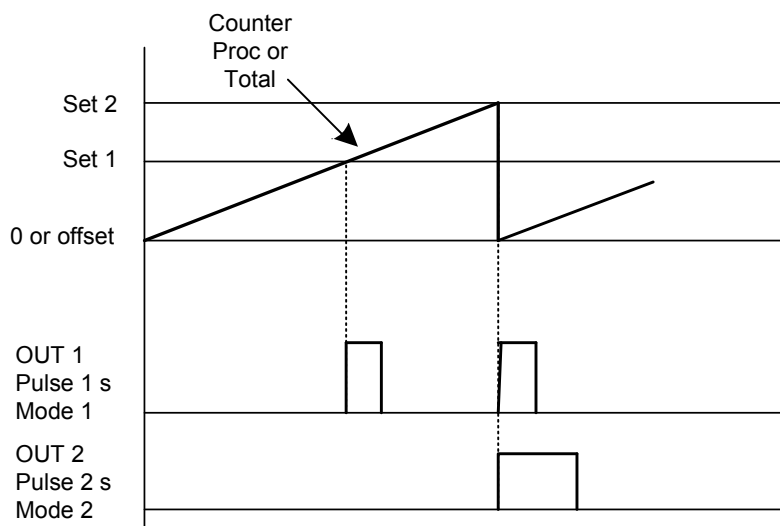

Mode 3 Stop

All process, batch and total counters, where applicable, will stop during the output enabling time. Where the output is pulse, the counters will restart once the enabling time is complete. If the output is latch, the counters will restart when the counter to which the setpoint is related is reset.

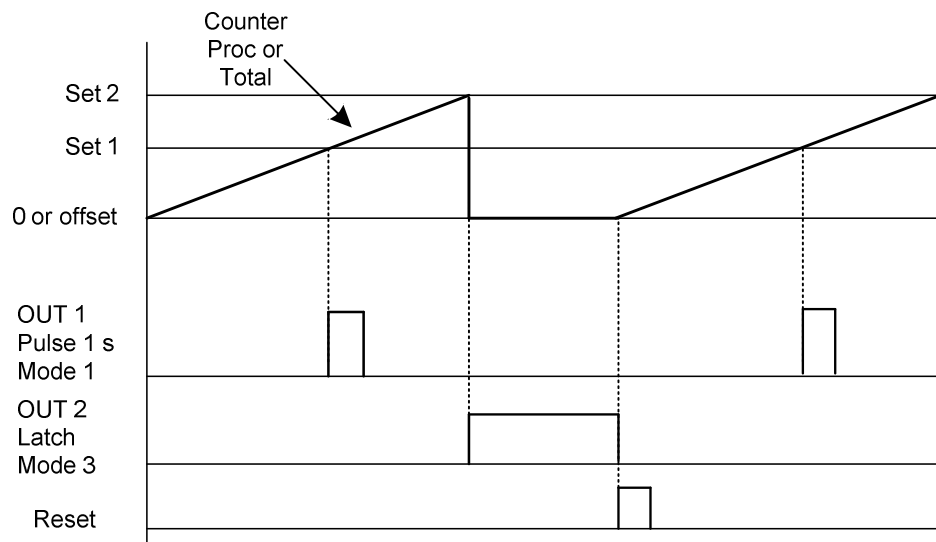
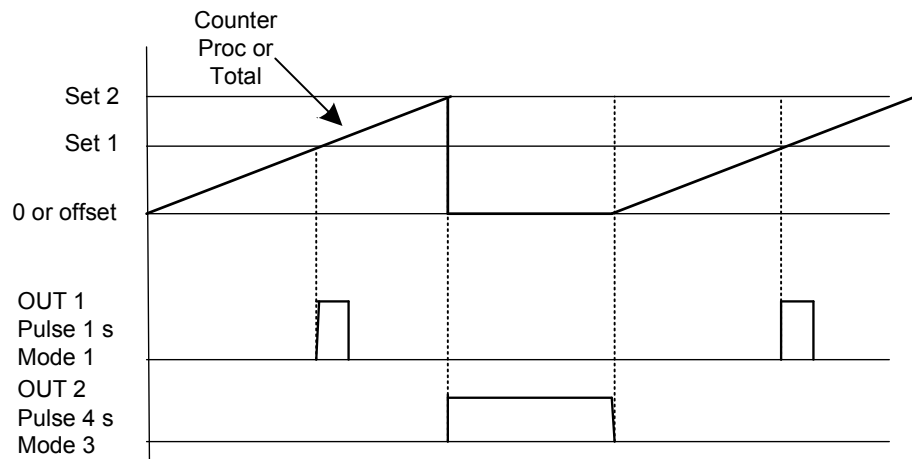

Mode 4 Clear

On enabling the output, the previous setpoint output is disabled, if it had been enabled.

(The setpoint prior to 1 is 4)

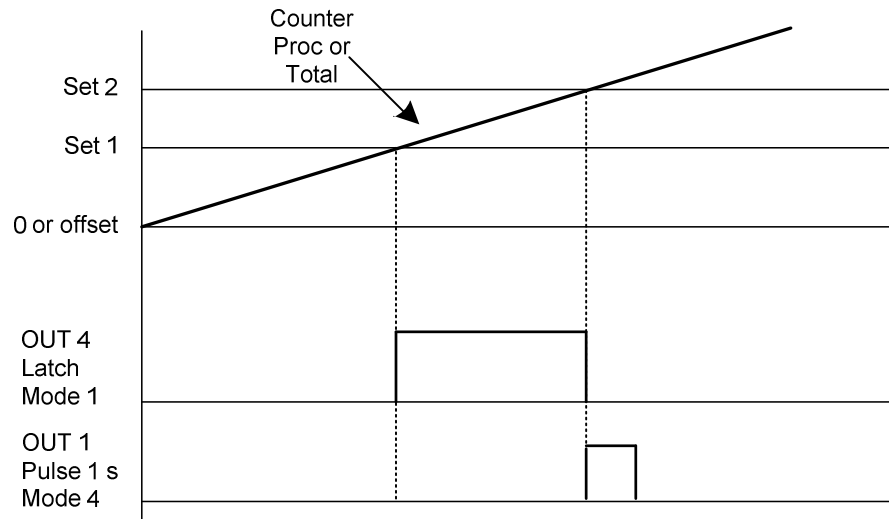

9.2 ANALOG OUTPUT OPT4500/mA AND V

9.2.1 – Introduction

Two ranges of analogue output (0 to 10) V and (4 to 20) mA can be incorporated into the DM4500F, either the OPT4500/V option for voltage output or the OPT4500/mA option for current output. Note: Both cards cannot be used simultaneously.

The outputs are isolated with respect to the signal input and the power supply. The optional board provides a two terminal connector [(+) and (-)] that drives out a signal variation from (0 to 10) V or from (4 to 20) mA proportional to a user-defined display range.

The instrument will detect the type of option that has been installed and will operate accordingly. The display values producing the full scale output (OUT-HI and OUT-LO) are also introduced via front-panel buttons in the same programming module. The analogue output then follows the display variation between the HI and LO programmed points.

The output signal can be set up for reverse action by programming the low display for the high output (OUT-HI) and the high display for the low output (OUT-LO).

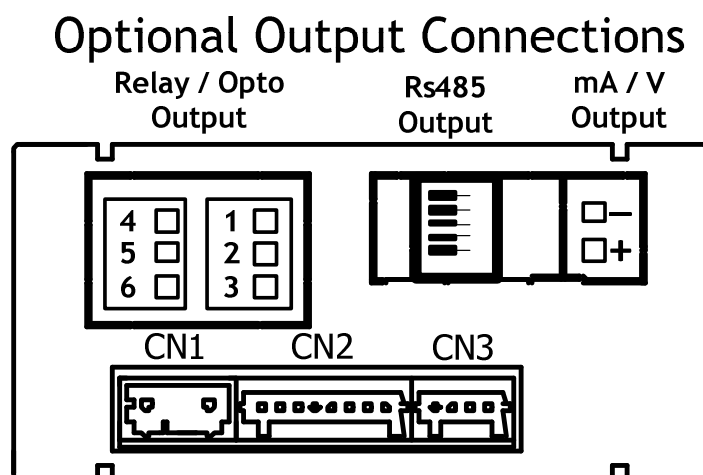

9.2.2 – Technical specifications

CHARACTERISTICS	OPT4500 / mA OUTPUT	OPT4500 / V OUTPUT
RESOLUTION	13 BITS	13 BITS
ACCURACY	0.1% F.S. ±1BIT	0.1% F.S. ±1BIT
RESPONSE TIME	50 ms	50 ms
THERMAL DRIFT	0.5 μ A/°C	0.2 mV/°C
MAXIMUM LOAD	$\leq 500 \Omega$	$\geq 10 \text{ K}\Omega$

9.2.3 – Analog output menu diagram

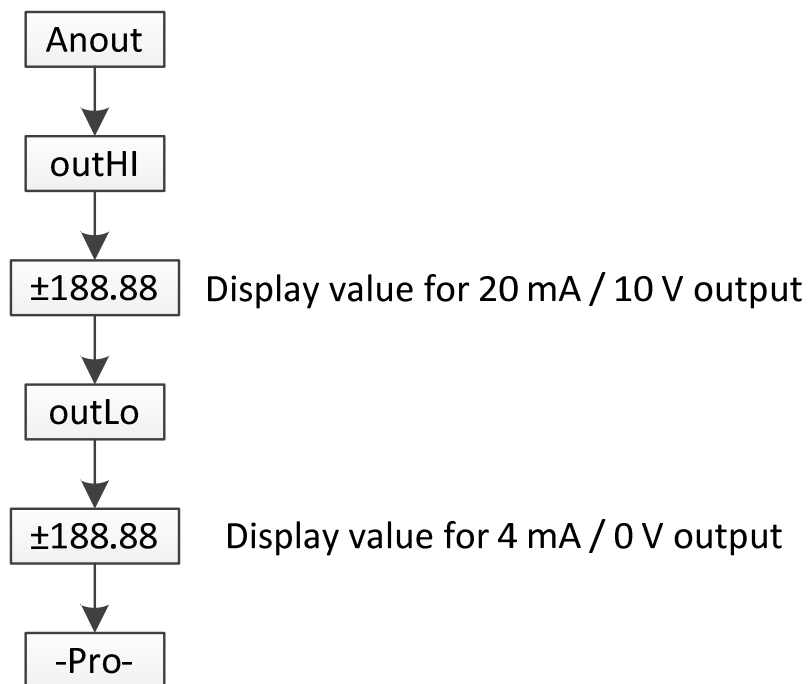

10. Technical Characteristics

INPUT SIGNAL

Frequency meter and Tachometer

Frequency Limits

MIN frequency	0.01 Hz
MAX frequency without totalizer	19 KHz
MAX frequency with totalizer.....	9.9 KHz

Counter

MAX count rate (*)

Up or down without relays	20 KHz
Up or down with relays.....	15 KHz
Bidirectionnal Phase or Direc without relays	20 KHz
Bidirectionnal phase or Direc with relays.....	15 KHz
Bidirectionnal Indep without relays.....	20 KHz
Bidirectionnal Indep with relays.....	15 KHz

EXCITATION 8 V/24 V DC @ 30 mA
18 Vdc (not stabilized) @ 100 mA

Contact closure

FILTER

Fc with duty cycle 50%	20 Hz
Fc with duty cycle 30%	10 Hz

INPUTS (2 CHANNELS)

MAGNETIC PICKUP

Sensitivity $V_{in} (AC) > 60 \text{ mVpp} @ F < 1\text{kHz}$
 $> 120 \text{ mVpp} @ F > 1 \text{ kHz}$

NAMUR

Rc 3k3 (incorporated)
Ion < 1 mA DC
Ioff..... > 3 mA DC

TTL/24V DC (encoder)

Logic levels "0" < 2.4 V DC, "1" > 2.6 V DC

NPN or PNP

Rc 3K3 (incorporated)
Logic levels "0" < 2.4 V DC, "1" > 2.6 V DC

CONTACT CLOSURE

Vc 5 V
Rc 3.9 K
Fc (activated automatically) 20 Hz

HIGH VOLTAGE INPUT (1 CHANNEL)

Voltage limits (10 to 300) V AC

COUNTER IN CHRONOMETER MEMORY

Non-volatile E2PROM retains all programming data and count value when power is removed or interrupted.

DISPLAY

Type..... 5 programmable tricolor 14 mm digits
LED's.....8, control and status indication
Decimal Point.....programmable
Sign automatic s/configuration
Positive overflow indication OvEr
Negative overflow indication -OvEr
Counter display limits Process -99999 to 99999
Totalizer -99999999 to 99999999
Chronometer ranges..... 4, from 999.99 s to 9999.9 h
Frequency ranges..... 0.01 Hz to 20 KHz/10 KHz(totalizer)

Tachometer range ..0 to 99999(rpm), programmable (rate)

Scale factor

Counter programmable from 0.0001 to 99999

Freq/Tach..... programmable from 0.0001 to 99999

Display update rate

Counter 100 ms

Chronometer..... 100 ms

Frequency/Tachometer.....programmable 0.1 to 9.9 s

POWER

DM4500/S1.....(85 to 265) VAC, (100 to 300) VDC

DM4500/S2..... (22 to 53) VAC, (10.5 to 70) VDC

Consumption.....5 W (without options), 10 W max

ACCURACY

Frequency/Tachometer 0.005 %

Chronometer..... 0.01 %

Temperature coefficient..... 0.005 %/°C

Warm up time 5 minutes

AMBIENT

Indoor use

Operating temp..... (-10 to 60) °C

Storage temperature (-25 to 85) °C

Relative humidity (non condensing)..... < 95 % at 40 °C

Max altitude2000 m

MECHANICAL

Dimensions (96x48x60) mm (DIN 43700)

Panel cut out(92x45) mm

Weight 200 g

Case material..... Polycarbonate (UL 94 V-0)

Sealed front panel IP65